

VersaRupter® MV Indoor Switch

5-38 kV, 200-1200 A, 40 & 61 kA

Installation and Operation Manual

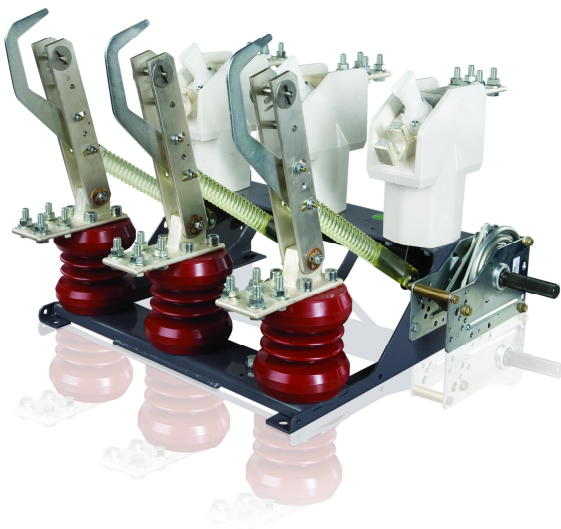
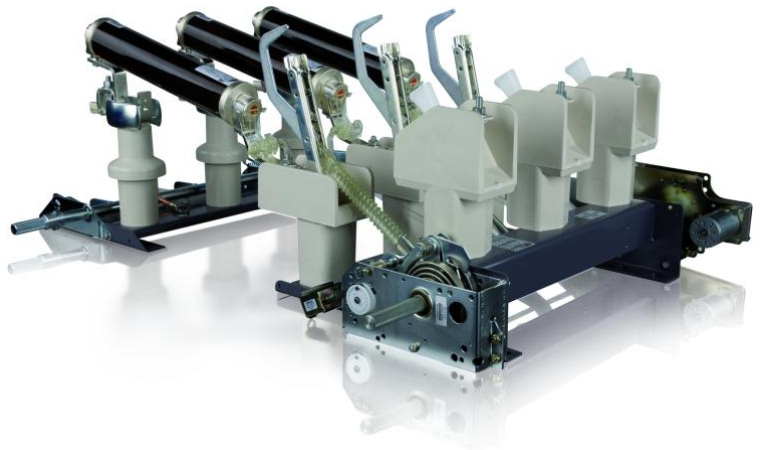

Provided by Northeast Power Systems, Inc.
www.nepsi.com

Your safety first - always!

That's why our instruction manual begins with these recommendations:

- Fully comply with the legally recognized standards (ANSI / IEC), the connection conditions of the local electrical utility and the applicable safety at work regulations.
- Pay special attention to the hazard notes in the instruction manual marked with this warning symbol.



- Make sure that specified data is not exceeded under operational conditions of the switchgear or switchboard.
- All maintenance and installation activities must be performed by specialists with valid licenses only.
- Keep the instruction manual accessible to all persons concerned with installation, operation and maintenance.
- The user's personnel are to act responsibly in all matters affecting safety at work and the correct handling of the switchgear.

Provided by Northeast Power Systems, Inc.
www.nepsi.com

WARNING

Always observe the instruction manual and follow the rules
of good engineering practice!

Hazardous voltage can cause electrical shock and burns.

Disconnect power, then earth and short-circuit before proceeding with any
work on this equipment.

If you have any further questions on this instruction manual, the members of our field organization will be pleased to provide the required information.

Table of Contents

Introduction.....	5
Installation and Mounting.....	6
Mounting and Wiring the Shunt Trip.....	8
Mounting the Open Fuse Auxiliary Switch.....	10
Mounting the Open Fuse Auxiliary Switch on Motor Bracket.....	12
Mounting an Open Fuse Auxiliary Switch with a Shunt Trip.....	14
Mounting the Auxiliary Switch.....	17
Installing the Left Hand Shaft Extension.....	18
Mounting the NM Motor Operator on K-Mechanism.....	19
Mounting the NM Motor Operator on A-Mechanism.....	21
Mounting the NM Motor Operator on Left Side of VersaRupter A-mech.....	23
Mounting the NM Motor Operator on Left Side of VersaRupter K-mech.....	24
Installing the Type E Ground Switch on VersaRupter.....	25
Installing the Type E Ground Switch on VersaRupter Fuse Base.....	26
Installing the Mechanical Interlock.....	27
Installing the Bottom Mounted Fuse Base with Fuse Tripping.....	29
Installing the Top Mounted Fuse Base with Fuse Tripping.....	32
Mounting the HE/HM Operating Handles.....	35
Installing the Chain Drive Handle.....	36
Installing the Direct Drive Handle.....	37
Installing the Back Connect Kit.....	38
Installing the K-mechanism.....	39
Installing the A-mechanism.....	40
Service and Maintenance.....	41
Replacement of Parts 5-27 kV.....	43
Replacement of Parts 38 kV.....	51
Torque Values for Self Tapping Screws.....	56
Drawings	
Outline.....	57
Back Connect Kit.....	67
Auxiliary Switch Kit.....	72
Chain Drive Assembly.....	73
Left Hand Shaft Extension.....	74
Mechanical Door Interlock.....	75

Table of Contents

Direct Drive Handle Right Side	76
Direct Drive Handle Left Side	77
HE/HM Handles	78
Notes	79

Introduction

Application

This instruction bulletin describes the following for the VersaRupter switch family:

- Operating features
- Function
- Installation
- Mounting options
- Repair
- Replacement of parts
- Maintenance

Personnel should be familiar with this instruction bulletin before installing or operating the switch.

The VersaRupter meets ANSI standard number C37.20.4. Abnormal service conditions may require a de-rating of the VersaRupter switch or a modification to its application. For issues not discussed in this instruction bulletin, contact the factory as indicated on the back cover.

Receiving, Handling, and Storage

Perform an inspection of the shipping container and the VersaRupter upon receipt. Shipping damage must be reported to the shipper that delivered the switches.

Determine that all items on the purchase order have been delivered. VersaRupter switches and its various options are shipped in separate containers. These assemblies must be installed on the switch, as required, to complete the switch package. Contact ABB customer service if it is determined that parts are missing or other field warranty authorization is required. Information to contact customer service can be found on the last page of this manual.

VersaRupters assembled with K-mechanisms are shipped in the closed position. VersaRupters assembled with stored energy A-mechanisms are shipped with the drawbars disconnected from the mechanism driven operating shaft to prevent accidental opening during shipping and handling. See the paragraph entitled "Test Operations" for special handling instructions.

Never lift the VersaRupter by the switch blades, operating shaft, or insulators; damage and misalignment will occur when lifted by these parts.

Remove all packing materials then use a carry strap secured around the upper cross bar of the switch frame to lift the switch from its container. Avoid lifting chains, as they will damage the paint finish on the switch frame. Store switch in its shipping container until installation. It is acceptable to stack switch shipping containers, but no more than four high.

Installation and Mounting

Inspect the VersaRupter for any obvious problems prior to installation. Check that the surfaces of the main stationary contact are covered with contact grease. Recommended grease is ISOFLEX TOPAS NCA 52.

Test operations

The switch can be operated several times with a removable handle once secured to a flat surface. Switches with a K-mechanism will open when the shaft is rotated clockwise and will close when rotated counter-clockwise (as seen from the mechanism side of the switch). The K-mechanism in the closed position appears like the one in figure 1. Figure 2 shows the K-mechanism in the open position. Note the position of the cam in the center of the mechanism.

The drawbars are disconnected from the VersaRupter when shipped with an A-mechanism. After removing from the shipping container, gently pull the main contacts fully open by hand. Connect the drawbars onto the shaft of the eccentric bolt. Install the provided washer and circlip to secure the drawbar to the eccentric bolt. The proper contact penetration was set at the factory before removing the draw bars from the shaft.

To operate the switch with an A-mechanism, the shaft must be turned clockwise to first charge the opening spring. A charged A-mechanism can be identified by the opening spring assembly rotated and locked into position towards the rear of the mechanism as seen in figure 3. Compare this to the initial state in figure 4. Turning the shaft counter-clockwise will close the switch and a small clockwise rotation will open the switch.

Figure 1



Figure 2

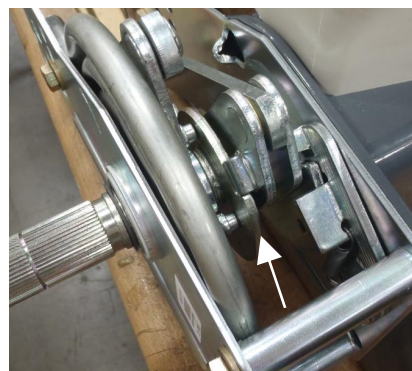

Figure 3

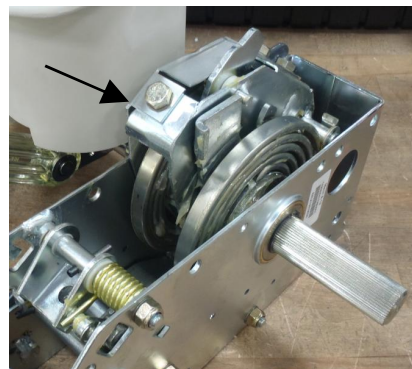
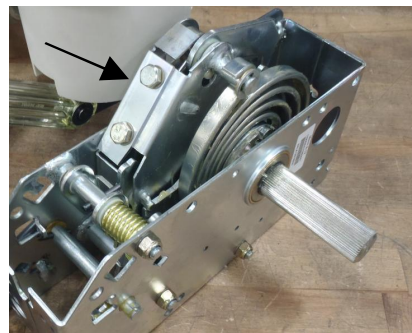

Figure 4



Provided by Northeast Power Systems, Inc.
www.nepsi.com

WARNING

The VersaRupter switch blades move rapidly with great force. Always stay clear of these moving parts to avoid serious bodily injury.

The A-mechanism is a stored energy device that can release its energy with great force and speed after a very small rotation of the shaft.

Installation and Mounting

Preparation of the Supporting Structure

The VersaRupter can be applied in vertical or horizontal operations. The design of a supporting structure shall consider the geometrical configuration of the VersaRupter and minimal clearances to both earthed and live parts. The supporting structure shall be rigid enough to prevent deformation of the VersaRupter base. All of the mounting surfaces of the frame shall remain in the same plane. It is recommended to use U-iron or angle iron components in the construction of the supporting structure. The VersaRupter should be mounted using four M12 bolts through the mounting holes in the frame.

Installation of the VersaRupter

Use caution not to deform the base of the VersaRupter during installation. This could lead to the following problems:

1. Increased moment of force on the VersaRupter shaft.
2. Contacts not operating simultaneously. Contacts should not exceed 3 mm in normal conditions.
3. Deterioration of contacts in the closed position.
4. Displacement of the symmetry plane of moving contacts in relation to the pole symmetry plane which results in asymmetrical contact of the fixed contacts and moving contacts.

To avoid these defects mentioned above, it is recommended to only tighten three of the mounting bolts when installing the VersaRupter. The fourth bolt can be shimmed with additional washers if needed to prevent any deformation while tightening the fourth bolt.

Do not use the lower or upper insulators for support during mounting. This may cause misalignment in the insulators and catastrophic damage during operation.

Mounting and Wiring the Shunt Trip

The shunt trip can only be installed on the A-mechanism. Shunt trip coils are intermittent duty which require an auxiliary contact to be wired in series with the shunt trip. The auxiliary switch will open the shunt trip circuit when the VersaRupter opens. Refer to Auxiliary Switch installation for more details.

1. Ensure that the A-mechanism is not pre charged prior to installing the shunt trip. The mechanism should appear as it does in figure 4. If not, rotate the shaft counter clockwise to release the spring then return the shaft to its neutral position.
2. Locate the mounting holes in the A-mechanism for the shunt trip shown in figure 5. Loosely install a bolt, lock washer, and nut into the lower hole allowing the shunt trip to rest on the A-mechanism as shown in figure 6.
3. Place the white disk on the half-moon shaft located on the operating shaft side of the A-mechanism. Place the shunt trip linkage between the white disk and A-mechanism and mark the hole that will provide the maximum rotation of the white disk if the linkage is pulled. An example is shown in figure 7.

Figure 5

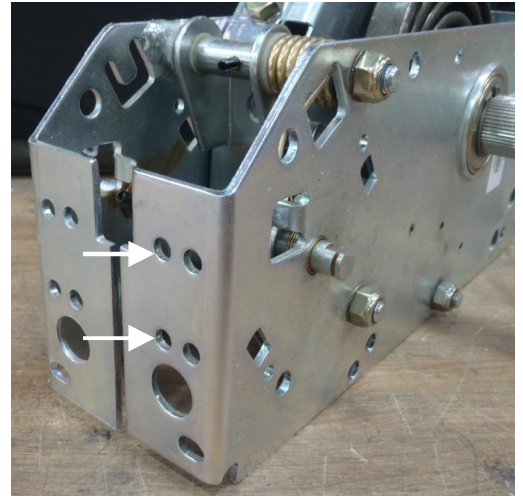

Figure 6

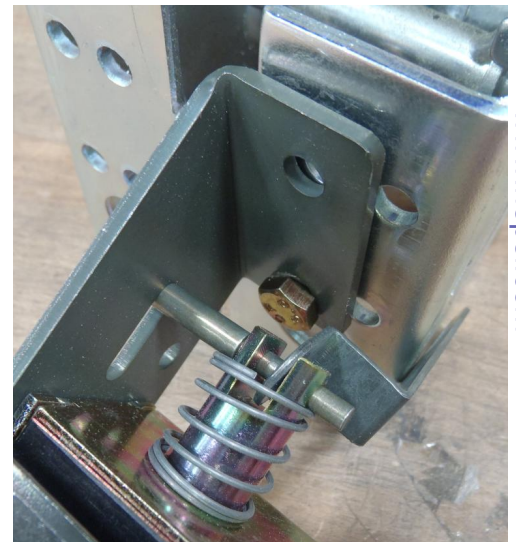
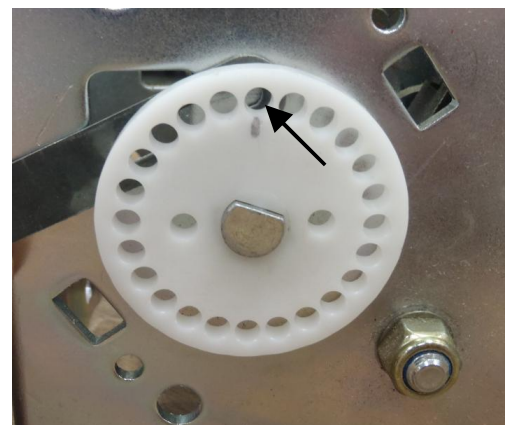

Figure 7



Mounting and Wiring the Shunt Trip

4. Remove the shunt trip and white disk from the A-mech and install the pin and clamp into the marked hole. Keep in mind the linkage should be between the white disk and A-mech when re-installed and the clamp should be on the outside face of the white disk as shown in figure 8.
5. Re-install the shunt trip permanently onto the A-mech with the two sets of bolts, lock washers, and nuts using a 10 mm socket. Slide the white disk back onto the half-moon shaft and secure with a cir-clip as shown in figure 9.
6. The shunt trip features a pull-apart wiring terminal that can be separated by a small flat head screw driver. Gently pry the white plastic housing away from the female housing, figure 10, to which the coil wires are attached. The plug can be wired separate from the coil and plugged back in to complete the circuit.

Figure 8

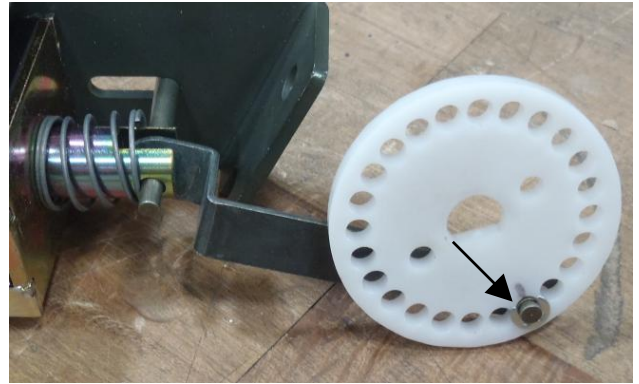

Figure 9

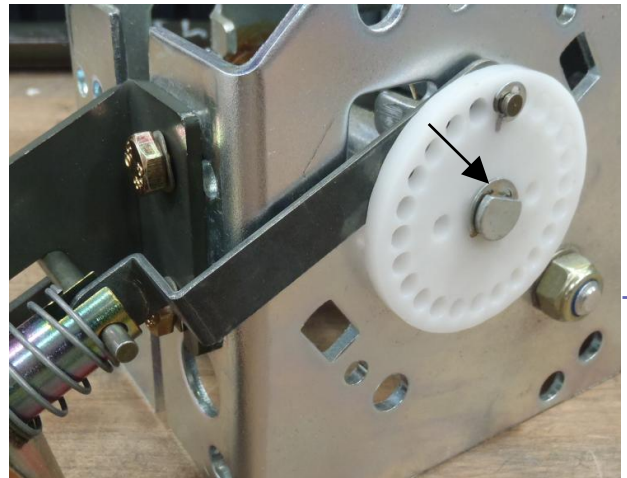

Figure 10



Mounting the Open Fuse Auxiliary Switch

The open fuse auxiliary switch can only be installed on the A-mechanism and a fuse base equipped with fuse tripping. This switch has two contacts, one normally open and one normally closed. It is actuated by the fuse tripping tie rod linkage connected to the type CEF fuse base.

1. Locate the mounting hole and slot on the side of the A-mechanism with the operating shaft shown in figure 11.
2. Bolt the open fuse auxiliary switch to the mounting hole on the A-mechanism and loosely install the screw hardware to allow the switch to rotate into the slot, pictured in figure 12.
3. Place the white disk onto the half-moon shaft and rotate the switch into place as shown in figure 13.
4. Rotate the white disk with your finger and mark the hole directly adjacent to the white roller on the switch as shown in figure 14.

Figure 11

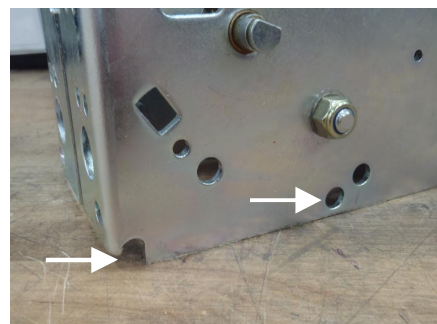

Figure 12

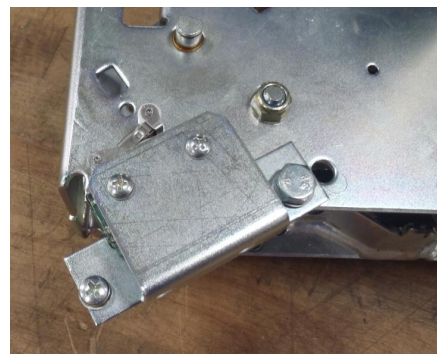

Figure 13

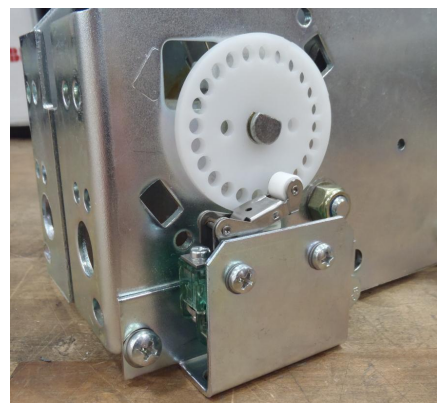
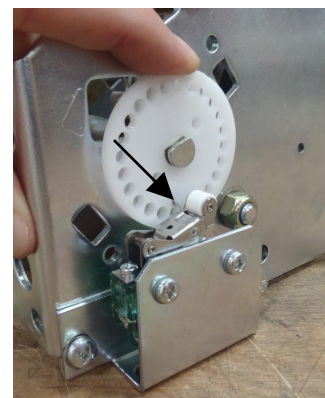

Figure 14



Mounting the Open Fuse Auxiliary Switch

5. Rotate the switch out of position and remove the white disk. Install the long bolt and two nuts into the marked hole from the previous step as in figure 15.
6. Re-install the white disk and switch back onto the A-mechanism. Rotate the white disk until it reaches its maximum rotation and contacts the switch as in figure 16. An audible click should be heard. If not, remove the white disk and move the long bolt and nuts to the appropriate hole. Once adjusted properly, secure the switch with a 13 mm socket and Phillips screw driver.
7. Install the cir-clip onto the half-moon shaft to secure the white disk as shown in figure 17.

Figure 15



Figure 16

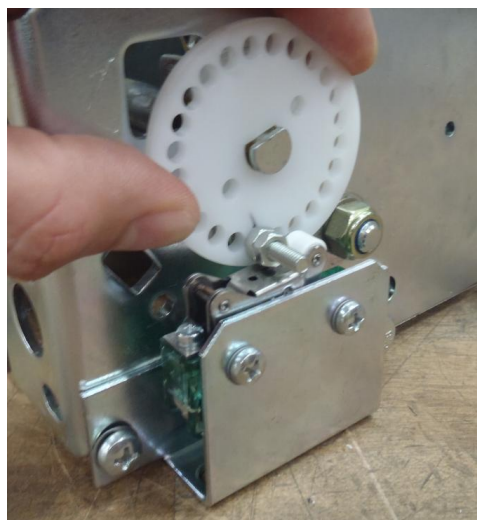
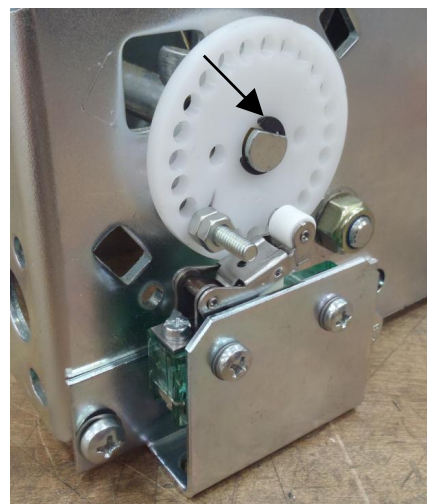

Figure 17



Mounting the Open Fuse Auxiliary Switch on Motor Bracket

Ensure that the A-mechanism is not charged.

1. Remove the two screws that secure the switch to the mounting bracket with a Phillips screw driver as seen in figure 18.
2. Slide the switch onto the studs located on the motor bracket and secure with the provided nuts. Place the white plastic disc onto the half moon shaft as shown in figure 19.
3. Rotate the white plastic disc to its maximum rotation and mark the hole adjacent to the white roller on the open fuse auxiliary switch as shown in figure 20.

Figure 18

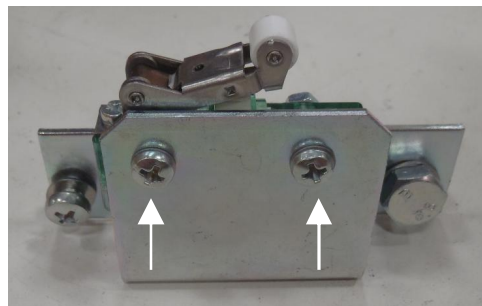

Figure 19

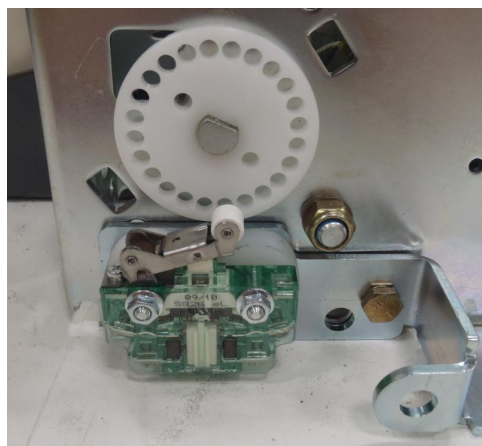
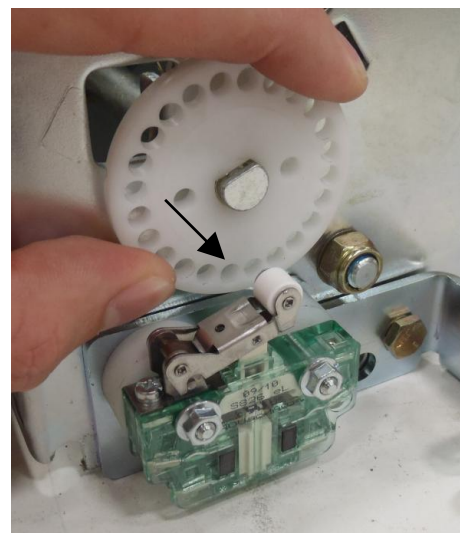

Figure 20



Mounting the Open Fuse Auxiliary Switch on Motor Bracket

4. Install the provided screw and nuts into the marked hole from the previous step as shown in the figure 21.
5. Rotate the white plastic disc, shown in figure 22, to its maximum displacement and listen for a “click”. This indicates that the switch will make contact. If a “click” is not heard, relocate the screw to a closer hole. Ensure the white disc reaches its maximum rotation just as the click is heard to prevent over rotation. If the setup is correct, secure the white disc with the provided cir-clip onto the half moon shaft.

Figure 21

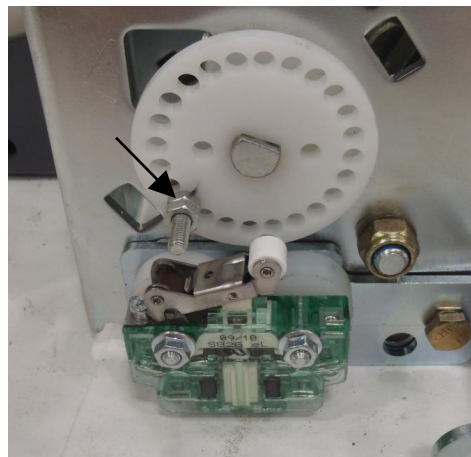
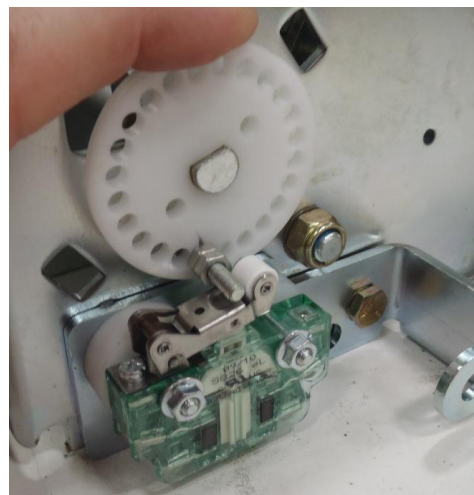

Figure 22



Mounting an Open Fuse Auxiliary Switch with a Shunt Trip

An open fuse auxiliary switch can be installed on the A-mechanism along with a shunt trip.

1. Follow the instructions for installing the shunt trip but do not secure the clamp onto the half-moon shaft so the white disk can be removed as shown in figure 23.
2. Bolt the open fuse auxiliary switch to the mounting holes as shown in figure 24.
3. Rotate the white disk until it reaches its maximum displacement and mark the hole adjacent to the white roller on the open fuse auxiliary switch as shown in figure 25.

Figure 23



Figure 24

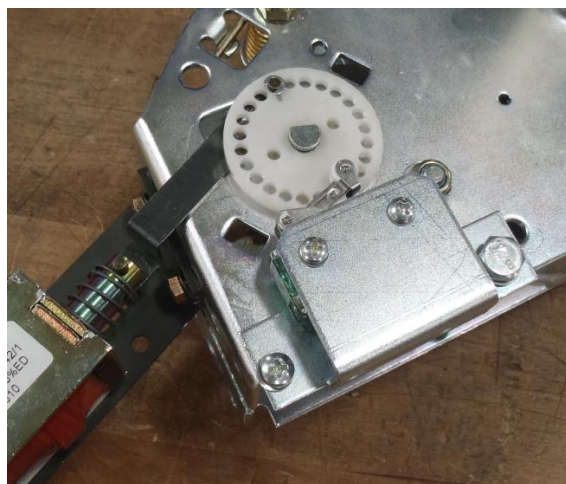
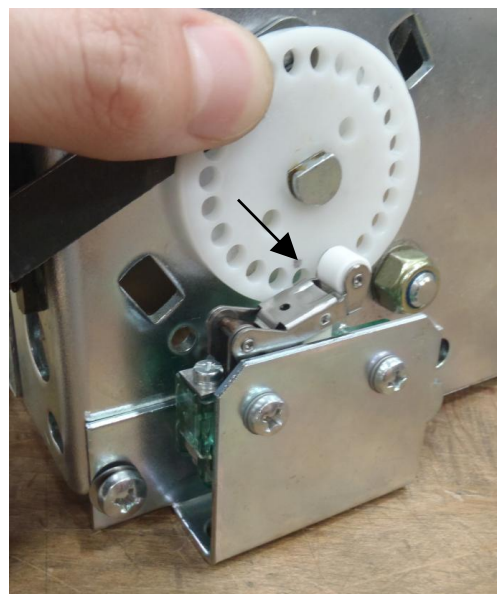

Figure 25



Mounting an Open Fuse Auxiliary Switch with a Shunt Trip

4. Rotate the open fuse auxiliary switch, remove the white disk from the half-moon shaft, and rotate the shunt trip linkage away from the A-mechanism. Install the long bolt and two nuts on the marked hole on the white disk as shown in figure 26.
5. Re-install the white disk back onto the A-mechanism and rotate the open fuse auxiliary switch back onto the A-mechanism as shown in figure 27.
6. Rotate the white disk until it reaches its maximum rotation and makes contact with the open fuse aux switch, shown in figure 28. An audible click should be heard from the switch. If not, relocate the long bolt and nuts to the appropriate hole.

Figure 26

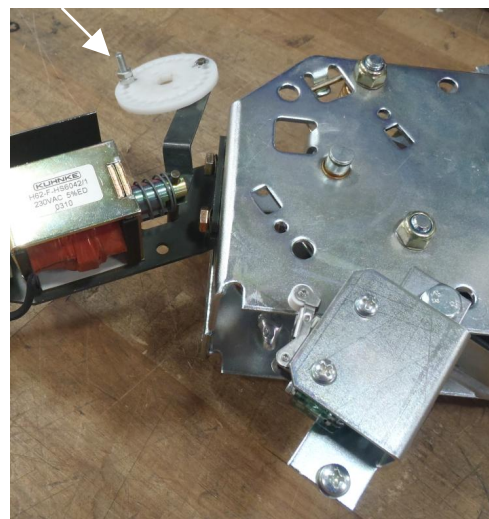

Figure 27

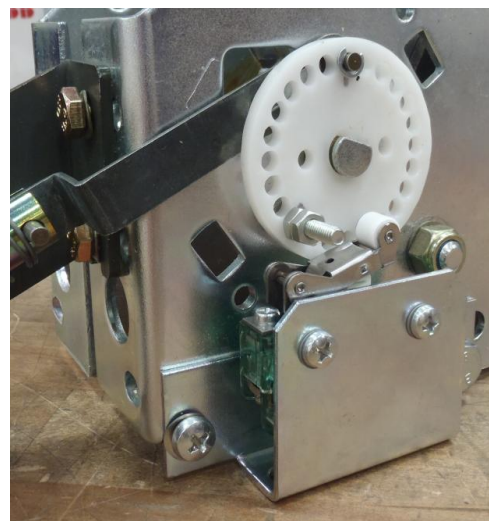
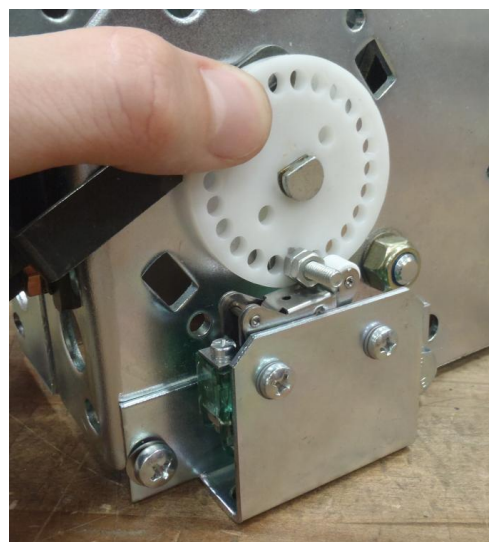

Figure 28



Mounting an Open Fuse Auxiliary Switch with a Shunt Trip

6. Pull the shunt trip linkage to its maximum displacement and ensure the audible click is not heard on the open fuse auxiliary switch as shown in figure 29. If it occurs, remove the white disk and move the long bolt and two nuts to the appropriate hole. Once adjusted properly, secure the switch with a 13 mm socket and Phillips screw driver.
8. Install the clamp onto the half-moon shaft to secure the white disk to the A-mechanism.

Figure 29

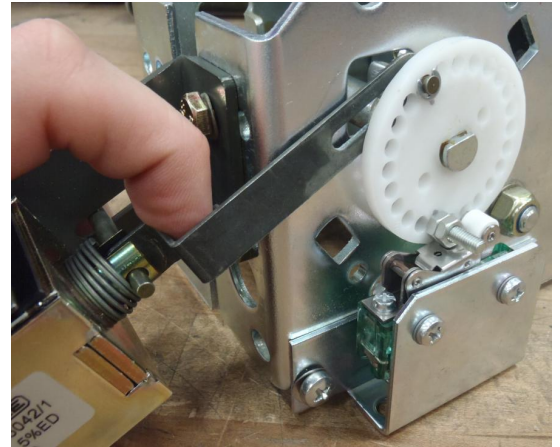
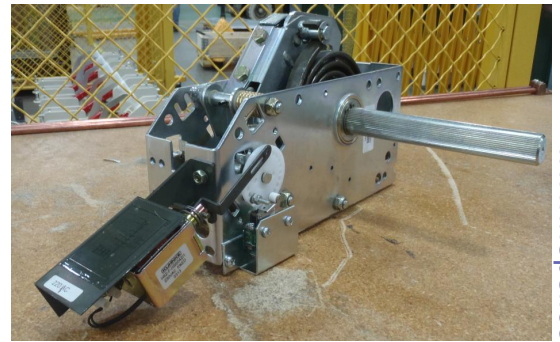

Figure 30



Mounting the Auxiliary Switch

The auxiliary switch contacts change state when the VersaRupter contacts change state and have an equal number of normally open and normally closed contacts which may be reconfigured in the field if necessary.

1. Locate the mounting holes on the back of the VersaRupter frame as well as the switch lever welded to the jack shaft shown in figure 31.
2. Install the auxiliary switch by bolting it with both provided bolts and lock washers to the pre-tapped mounting holes using a 6 mm Allen key as seen in figure 32.
3. Connect the lever on the auxiliary switch to the lever on the jack shaft and secure it with the provided clamp shown in figure 33.

Figure 31

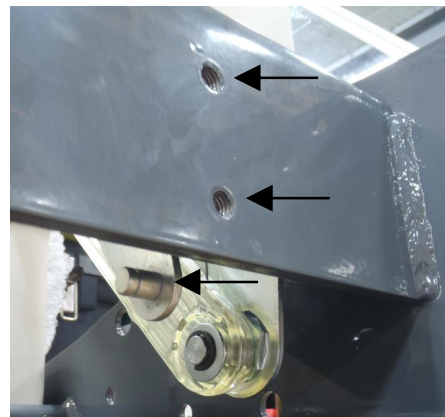

Figure 32

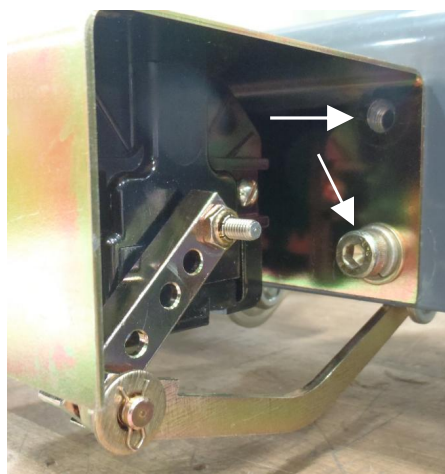
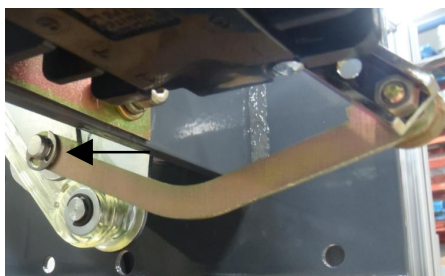

Figure 33



Installing the Left Hand Shaft Extension

The left hand shaft extension allows for the operation of the VersaRupter from the left side of the switch. The operating mechanism is always mounted on the right side of the switch so it is necessary to install a left hand shaft extension if operation from the left side is desired or required. Applications for motor operation and mechanical interlocking with the ground switch can also be utilized with the left hand shaft extension. The extensions vary in length dependent upon VersaRupter pole spacing but general installation is always the same.

1. Install the ring retainer onto the shaft extension and loosely slide the white plastic retainer onto the shaft as shown in figure 34.
2. Slide the shaft extension through the hollow jackshaft located on the left side of the switch where a similar white plastic retainer is bolted to the switch frame as shown in figure 35. The loose white plastic retainer should align with the stationary bolt threads.
3. Slide the shaft extension through this opening until it reaches the operating mechanism located on the right side of the switch. Rotate the shaft while applying pressure until the key way drops into the slot of the mechanism and will not rotate any longer.
4. Secure the white plastic retainer with the provided nuts and lock washers using a 13 mm socket as shown in figure 36. Use caution while tightening to prevent cracking the plastic.

Figure 34



Figure 35



Figure 36

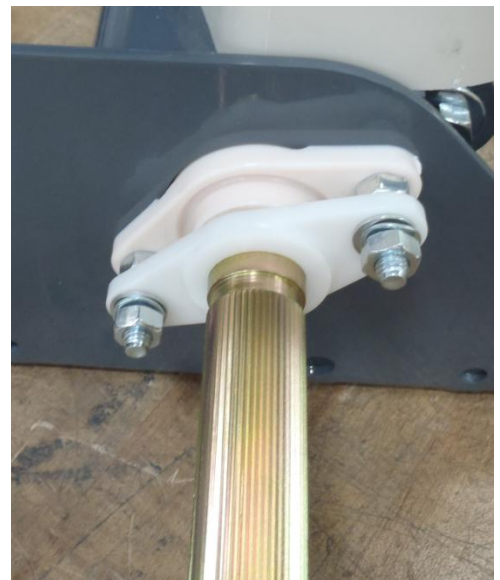

Mounting the NM Motor Operator on K-Mechanism

The NM motor operator can be installed on either the operating mechanism or a left hand shaft extension. The installation instructions are similar for either application but instructions can be found for installation on the left side of the VersaRupter. Further instructions can be found in the manual for the NM motor operator supplied with the motor concerning wiring and other data. Use M8 or 5/16" bolts and hardware to secure mounting bracket and motor.

1. Ensure that the VersaRupter is in the open position. Locate the mounting holes for the motor bracket on the K-mechanism. The bolt in the lower right corner of the K-mechanism will have to be removed and reinstalled to secure the motor mounting bracket. See figure 37.
2. Rotate the spline on the NM motor till the spacing is within 4-8 mm as shown in figure 38.
3. Rotate the splined shaft on the K-mechanism till the spacing is within 3-5 mm as shown in figure 39. This can be done by hand and does not require an operating handle.

Figure 37

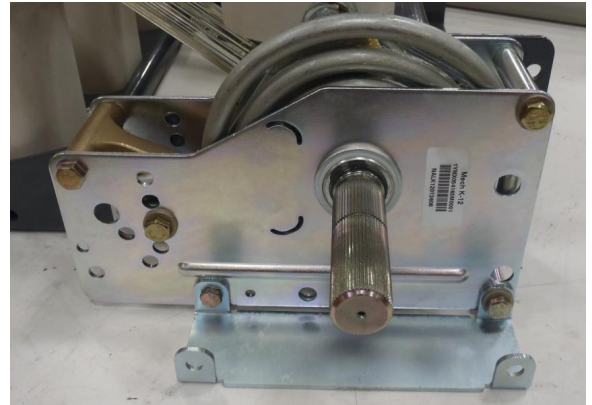
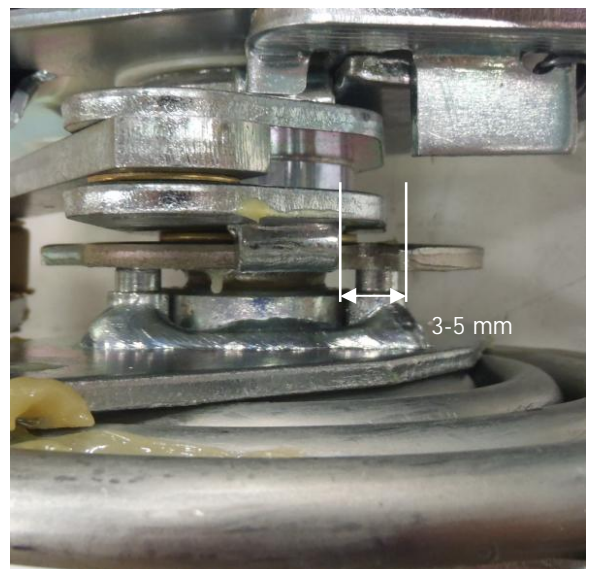

Figure 38



Figure 39



Mounting the NM Motor Operator on K-Mechanism

- Slide the NM motor onto the splined shaft of the K-mechanism and secure it with bolts, washer, lock washers, and nuts as shown in figure 40.

Figure 40

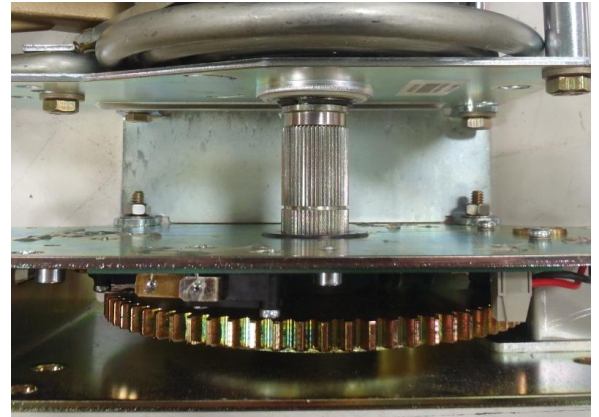
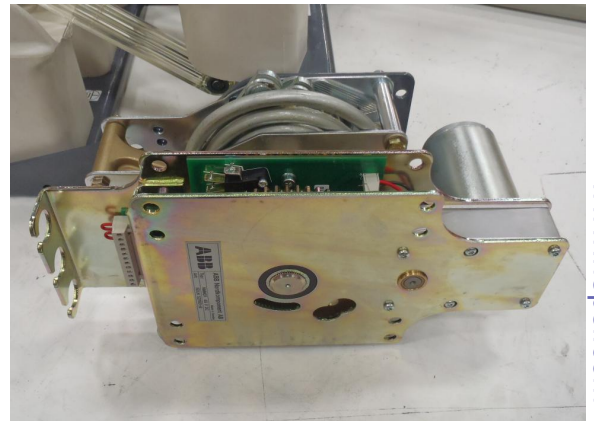

Figure 41



Mounting the NM Motor Operator on A-Mechanism

The NM motor operator can be installed on either the operating mechanism or a left hand shaft extension. The installation instructions are similar for either application but instructions can be found for installation on the left side of the VersaRupter. Further instructions can be found in the manual for the NM motor operator supplied with the motor concerning wiring and other data. Use M8 or 5/16" bolts and hardware to secure mounting bracket and motor.

1. Ensure that the VersaRupter is in the open position and the A-mechanism is not charged. Locate the mounting holes for the motor bracket on the A-mechanism. See figure 42.
2. Rotate the spline on the NM motor till the spacing is within 4-8 mm as shown in figure 43.
3. Rotate the splined shaft on the A-mechanism counter clockwise to remove the rotational variability in the shaft as shown in figure 44. This can be done by hand and does not require an operating handle.

Figure 42

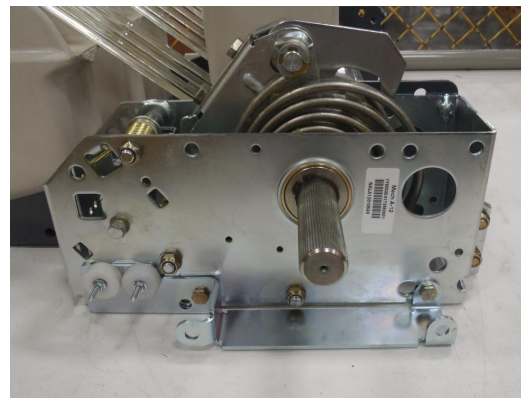

Figure 43



Figure 44



Mounting the NM Motor Operator on A-Mechanism

- Slide the NM motor onto the splined shaft of the A-mechanism and secure it with bolts, washer, lock washers, and nuts as shown in figure 45.

Figure 45

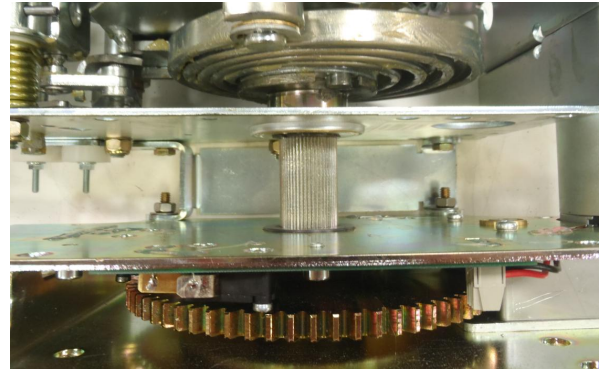
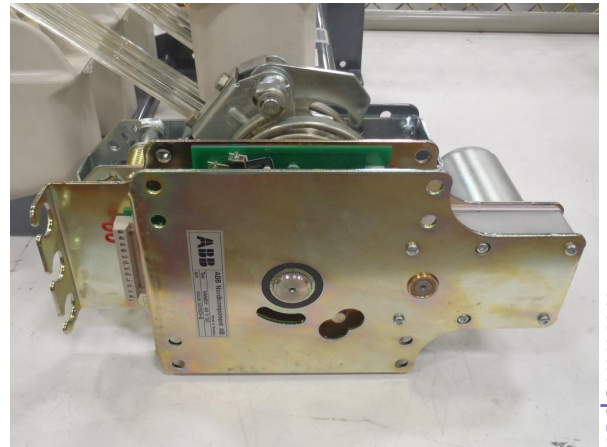

Figure 46



Mounting the NM Motor Operator on Left Side of VersaRupter A-mech

A left hand shaft extension is supplied if the NM motor is ordered for left side applications. Use M8 or 5/16" bolts and hardware to secure mounting bracket and motor.

1. Follow the instructions for installing the left hand shaft extension. Once complete, locate the mounting holes for the motor bracket located on the left side of the switch and bolt the bracket to the frame as shown in figure 47. Make sure the switch is in the open position.
2. Rotate the splined tube on the motor to achieve a 4-8 mm spacing as shown in figure 48.
3. Adjust the spacing on the operating mechanism to match the required spacing found in figure 44 located in the instructions to mount the motor to an A-mechanism.
4. Slide the motor onto the left hand shaft extension and secure to the motor bracket with bolts, washers, lock washers, and nuts as shown in figure 49.

Figure 47

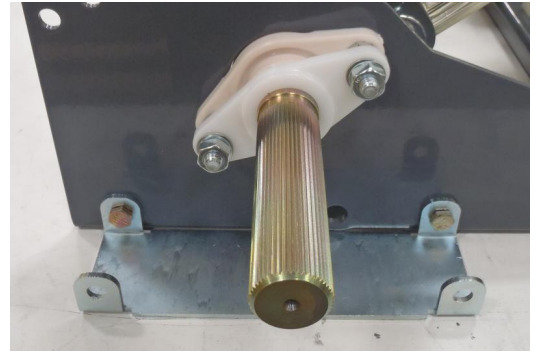

Figure 48



Figure 49

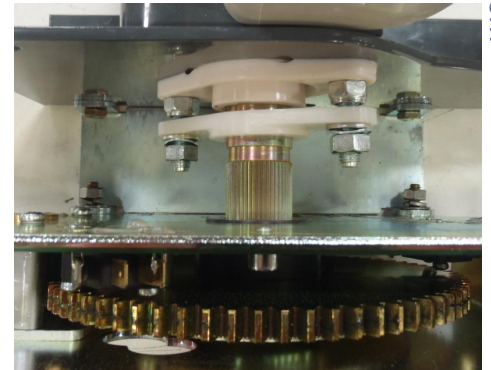
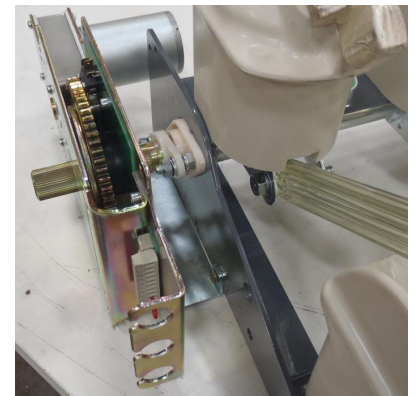

Figure 50



Mounting the NM Motor Operator on Left Side of VersaRupter K-mech

A left hand shaft extension is supplied if the NM motor is ordered for left side applications. Use M8 or 5/16" bolts and hardware to secure mounting bracket and motor.

1. Follow the instructions for installing the left hand shaft extension. Once complete, locate the mounting holes for the motor bracket located on the left side of the switch and bolt the bracket to the frame as shown in figure 51. Make sure the switch is in the open position.
2. Rotate the splined tube on the motor to achieve a 4-8 mm spacing as shown in figure 52.
3. Adjust the spacing on the operating mechanism to match the required spacing found in figure 39 located in the instructions to mount the motor to a K-mechanism.
4. Slide the motor onto the left hand shaft extension and secure to the motor bracket with bolts, washers, lock washers, and nuts as shown in figure 53.

Figure 51

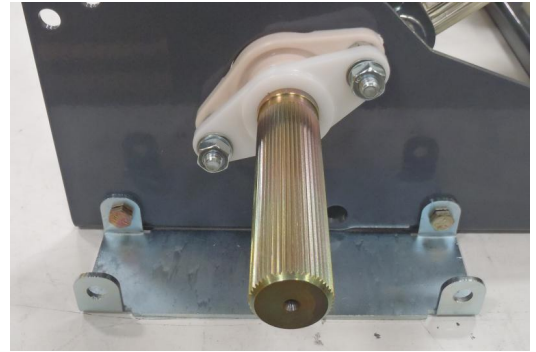

Figure 52

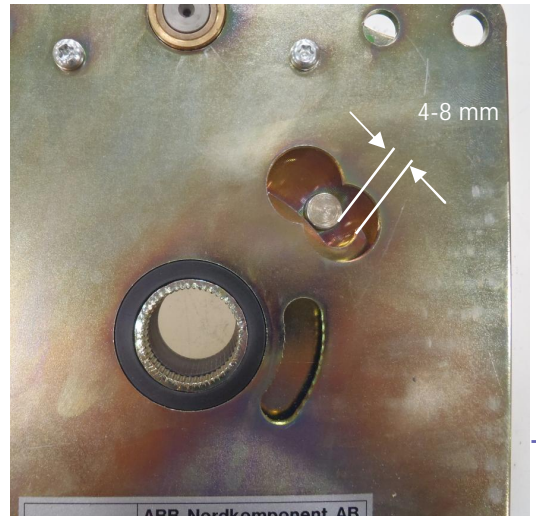

Figure 53

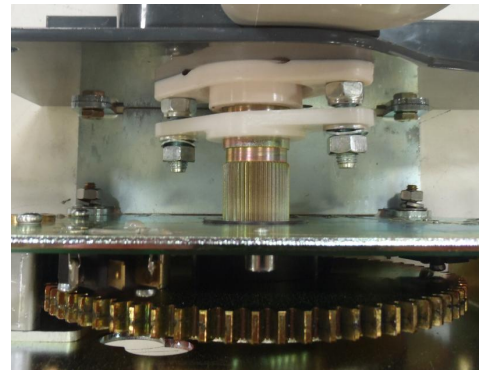
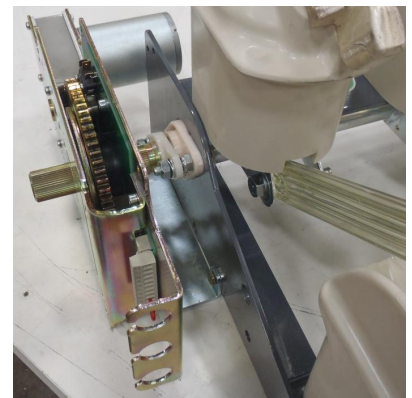

Figure 54



Installing the Type E Ground Switch on VersaRupter

The grounding switch allows the lower terminals of the VersaRupter (or fuse base) to be grounded. The grounding switch must be mechanically interlocked with the VersaRupter so that it cannot be closed the same time the VersaRupter is closed. Separate operating handles must be provided for the VersaRupter and grounding switch.

Grounding switches are specified in accordance with the pole spacing of the VersaRupter to which they are attached. Left and right hand splined shafts are provided with the ground switch. The VersaRupter must have a left hand shaft extension installed for either the mechanical interlock or operating handle.

1. The three bus pieces must be installed on the lower contacts of the VersaRupter which are supplied with the ground switch. Each of these pieces has a clearance hole for the Allen head screw and a bolt hole that aligns with the bolt hole of the lower terminal. The 1200 A switches have a clearance hole and two bolt holes. Do not fully tighten the nuts and bolts. See figure 55.
2. Visually align the contacts as in figure 56 and lubricate the stationary contacts with the provided lubricant in the kit.
3. Secure the Type E grounding switch to the lower portion of the VersaRupter frame using a 13 mm socket as shown in figure 57.
4. Close the grounding switch, figure 58, with a removable handle to align the stationary contacts and tighten the bolts using a 19 mm socket securing the stationary contacts.
5. Open the ground switch to prepare for mechanical interlock installation.

Figure 55



Figure 56

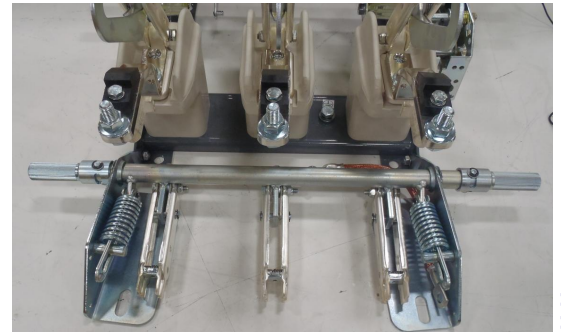
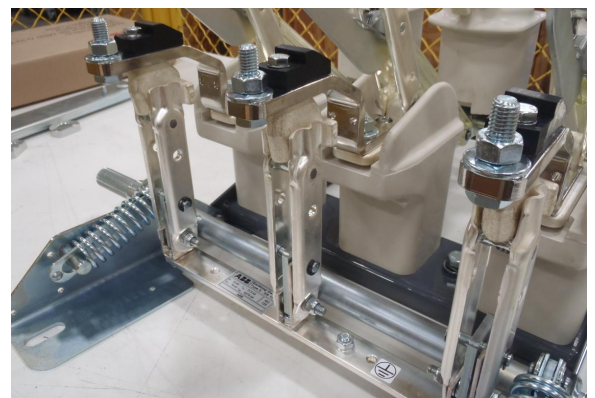

Figure 57



Figure 58



Installing the Type E Ground Switch on VersaRupter Fuse Base

The grounding switch allows the lower terminals of the fuse base to be grounded. The grounding switch must be mechanically interlocked with the VersaRupter so that it cannot be closed the same time the VersaRupter is closed. Separate operating handles must be provided for the VersaRupter and grounding switch.

Grounding switches are specified in accordance with the pole spacing of the VersaRupter to which they are attached. Left and right hand splined shafts are provided with the ground switch. The VersaRupter must have a left hand shaft extension installed for either the mechanical interlock or operating handle.

1. The three bus pieces must be installed on the contacts of the fuse base which are supplied with the ground switch. Do not fully tighten the nuts and bolts. See figure 59.
2. Visually align the contacts and lubricate the stationary contacts with the provided lubricant in the kit.
3. Secure the Type E grounding switch to the fuse base frame using a 13 mm socket as shown in figure 60.
4. Close the grounding switch, figure 61, with a removable handle to align the stationary contacts and tighten the bolts using a 19 mm socket securing the stationary contacts.
5. Install the tension bushings shown in figure 62.
6. Open the ground switch to prepare for mechanical interlock installation.

Figure 59



Figure 60

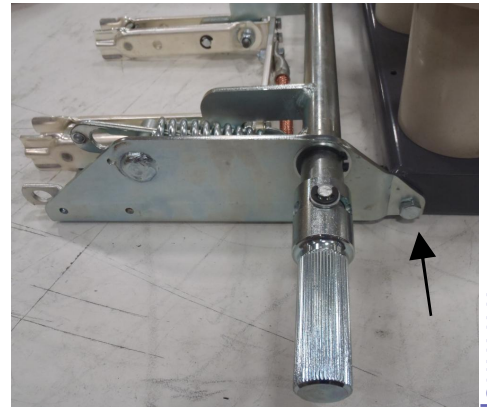
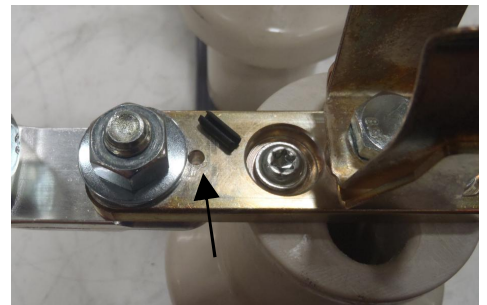

Figure 61



Figure 62



Installing the Mechanical Interlock

The mechanical interlock spans the distance between the VersaRupter left hand shaft extension and the left shaft of the ground switch. The mechanical interlock may also be installed on the right side of the switch allowing the operating handle to be operated from the left side of the switch. Different lengths are available to accommodate different switch ratings and fuse mounted applications.

Note: The grounding switch is normally set for the mechanical interlock to be installed on the left side and operating handle to be installed on the right side. This can be determined by checking the pin connecting the splined shaft to the grounding switch, shown in figure 63. Ensure that the side that the interlock will be installed on has the pin installed in the normal hole opposed to the slotted hole. The slotted hole is used for the side with the operating handle. The pin can be removed and re-installed to accommodate either the mechanical interlock or operating handle on either side of the switch. This is done by removing the cir-clips and washers securing the pin, rotating the splined shaft to line up with desired holes, and re-installing the washers and cir-clips.

1. Ensure the VersaRupter is open and A-mech charged if applicable.
2. Slide the provided clamps onto the splined shafts and slide one half of the interlock guide plate onto the shafts as shown in figure 63.
3. Place the two bolts through the interlock guide plate and slide the guide bushings onto the bolts as shown in figure 64.
4. Place the interlock slider onto the guide bushings and bolts. See figure 65.

Figure 63

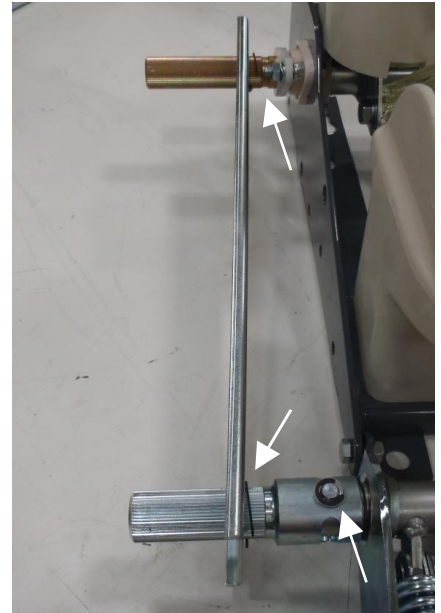

Figure 64

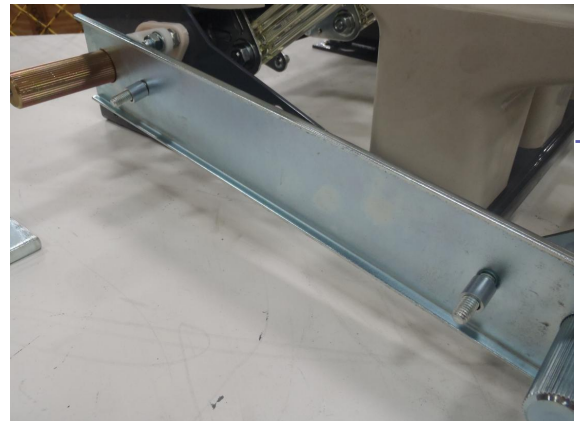

Figure 65



Installing the Mechanical Interlock

5. Slide an interlock cam onto each splined shaft with the flat portion facing the interlock slider as shown in figure 66.
6. Slide the other half of the interlock guide plate onto the splined shafts and install the nuts to tighten the assembly together using a 13 mm socket. Install the remaining clamps onto the splined shafts to secure the mechanical interlock. See figure 67.
7. Positively ground the braided ground connection found on the ground switch to the enclosure grounding system.

Note: For A-mech applications, A-mech must be charged in order to close the ground switch.

Figure 66

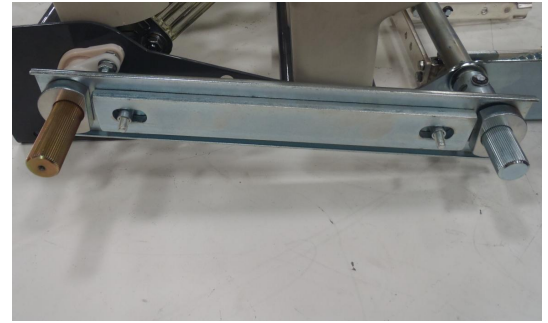

Figure 67



Provided by Northeast Power Systems, Inc.
www.nepsi.com

Installing the Bottom Mounted Fuse Base with Fuse Tripping

WARNING

These operations must be carried out by specialists only! Improper installation may result in serious injury or death.

The fuse base features a welded frame on which the insulators and live parts are mounted. Bases are available to be mounted on either the top (line side) or bottom (load side) of the VersaRupter. The terminals of the switch provide the mounting points for the fuse clips and the optional fuse trip accessories. The frame for the three standoff insulators and remaining fuse clips is mounted the proper distance (based on fuse length) from the fuse clips mounted on the VersaRupter terminals.

Fuse tripping installation:

1. Install the provided fuse clips to the lower terminals of the VersaRupter using a 19 mm socket as shown in figure 68.
2. Referring to figure 71, fix the lower bearing mount (8) to the fuse clip (10) installed on the lower terminals of the VersaRupter using provided screws and washers. Shown in figure 69.
3. Combine the lever (13) with the fuse trip flap (15) and install the assembly onto the lower bearing mount (8). Secure it with the bearing clip (14) as shown in figure 70.

Figure 68

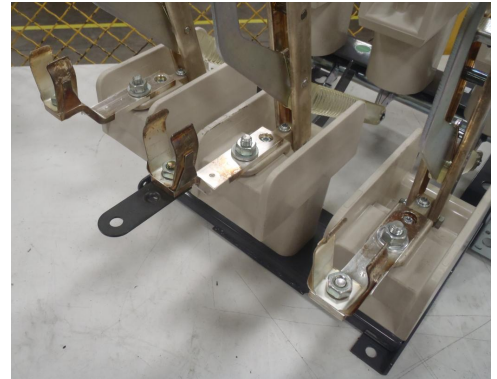

Figure 69



Figure 70



Figure 71

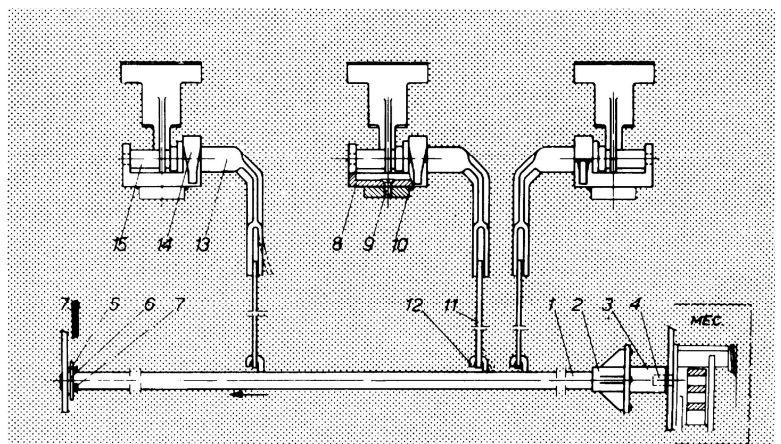

Installing the Bottom Mounted Fuse Base with Fuse Tripping

4. Install the release rod (11) in the lever (13) as shown in figure 72.
5. Mount the drive ring (2) to the release shaft (1) on the right hand side as shown in figure 73.
6. Mount the disk (3) onto the A-mech shaft (4) found on the operating mechanism as shown in figure 74.
7. Slide the bearing (5) and washer (6) onto the left side of the release shaft (1), engage the release shaft (1) with the disk (3), and place the left side of the release shaft (1) into the hole found on the left side of the VersaRupter frame. Refer to figure 75.

Figure 72

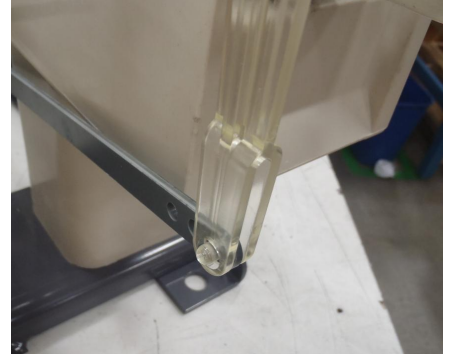

Figure 73



Figure 74

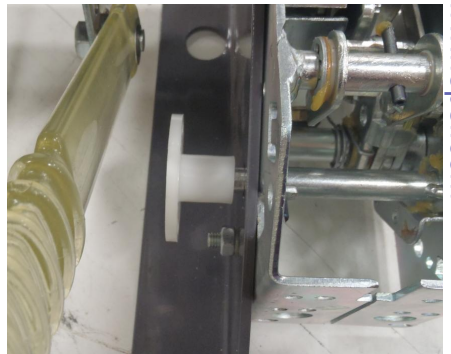
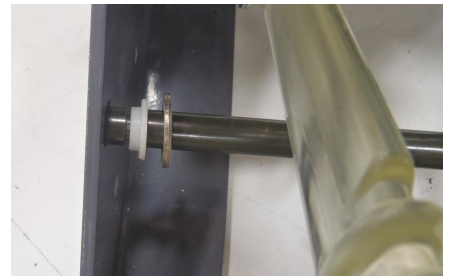

Figure 75



Installing the Bottom Mounted Fuse Base with Fuse Tripping



WARNING

These operations must be carried out by specialists only! Improper installation may result in serious injury or death.

Adjusting the fuse tripping:

Charge the A-mechanism as described below in "Fuse tripping control".

1. Adjust the release shaft to a position similar to that found in figure 76 so that the distance from the fuse trip flap to fuse is within the limits of figure 79.
2. Secure the washer and bearing on the left side of the release shaft with the provided cir-clip as shown in figure 77.
3. Secure the end of the release rod (11) to the release shaft (1) as shown in figure 78.

Notes:

1. Check distance between fuse trip flap and fuse to match that of figure 79 once installation is complete. Adjustments can be made at the release rod (11) and lever (13) connection point.
2. The hooks (12) on the release shaft (1) should have the same position shown in figure 76 when the VersaRupter is in the open position with the A-mechanism opening spring charged.

Fuse tripping control:

1. Turn the operating shaft of the mechanism a maximum of 60° clockwise and return the handle back to the neutral position (opening spring housing must not be latched).
2. Mount a new fuse-link, or test fuse in accordance with DIN 43625, in one of the phases.
3. If the distance between the fuse clips is longer than shown in figure 79, max $e + 8$ mm, the adjustment must be made with the fuse link resting on the fuse clips on the fuse base.
4. The distance between the striker pin and the fuse trip flag (15) must be between 3-6 mm. The fuse link is allowed to sag but the distance between the striker pin and fuse trip flag must not exceed 12 mm.
5. If the VersaRupter does not open when adjusted as mentioned above, the adjustment must be repeated.

Figure 76

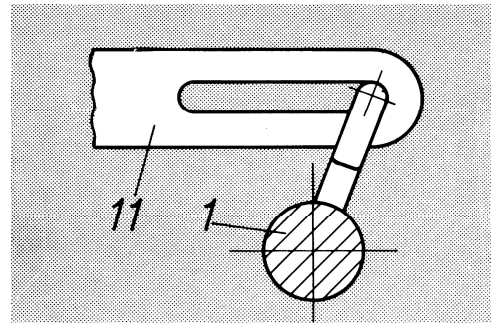

Figure 77

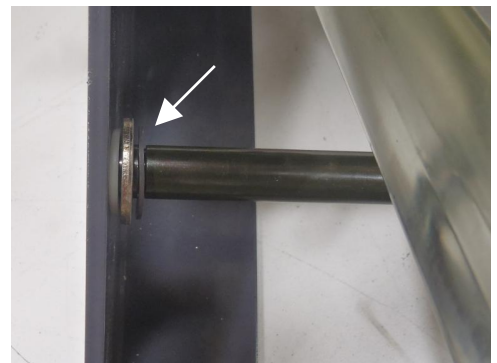

Figure 78

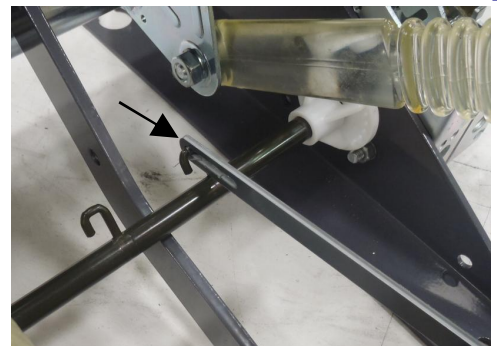
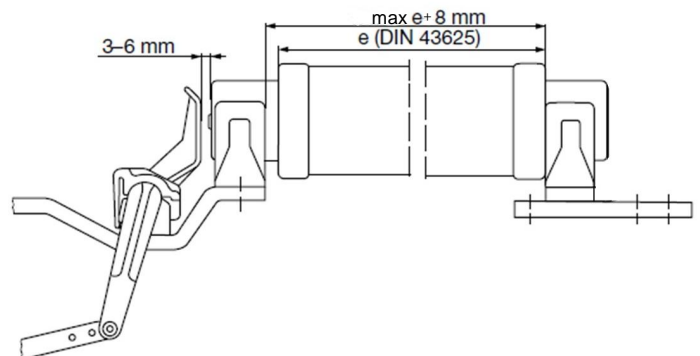

Figure 79



Installing the Top Mounted Fuse Base with Fuse Tripping



WARNING

These operations must be carried out by specialists only! Improper installation may result in serious injury or death.

The fuse base features a welded frame on which the insulators and live parts are mounted. Bases are available to be mounted on either the top (line side) or bottom (load side) of the VersaRupter. The terminals of the switch provide the mounting points for the fuse clips and the optional fuse trip accessories. The frame for the three standoff insulators and remaining fuse clips is mounted the proper distance (based on fuse length) from the fuse clips mounted on the VersaRupter terminals.

Fuse tripping installation:

1. The fuse clip must be assembled on the upper terminal of the VersaRupter. Locate the fuse clip parts and install according to figure 80.
2. Referring to figure 83, fix the lower bearing mount (8) to the fuse clip (10) installed on the lower terminals of the VersaRupter using provided screws and washers as shown in figure 81.
3. Combine the lever (13) with the fuse trip flap (15) and install the assembly onto the lower bearing mount (8). Secure it with the bearing clip (14) as shown in figure 82.

Figure 80



Figure 81

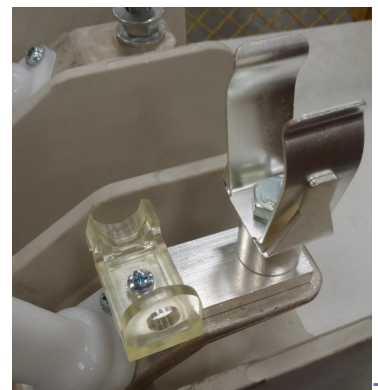

Figure 82

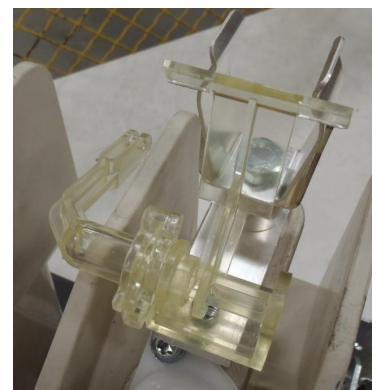
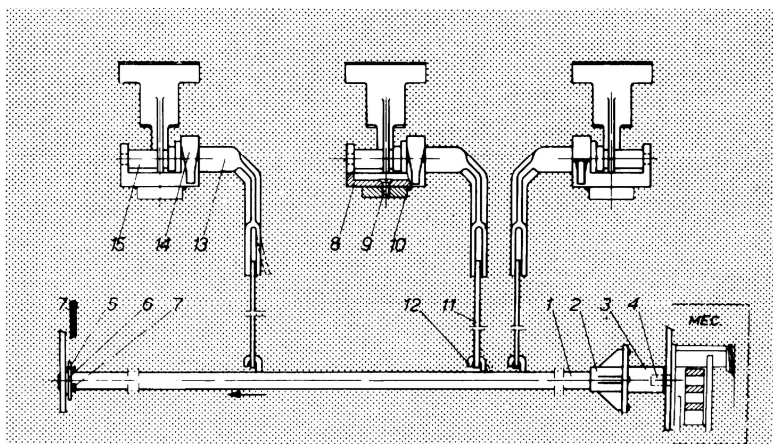

Figure 83



Installing the Top Mounted Fuse Base with Fuse Tripping

4. Install the release rod (11) in the lever (13) as shown in figure 84.
5. Mount the drive ring (2) to the release shaft (1) on the right hand side as shown in figure 85.
6. Mount the disk (3) onto the A-mech shaft (4) found on the operating mechanism as shown in figure 86.
7. Slide the bearing (5) and washer (6) onto the left side of the release shaft (1), engage the release shaft (1) with the disk (3), and place the left side of the release shaft (1) into the hole found on the left side of the VersaRupter frame. Refer to figure 87.

Figure 84



Figure 85

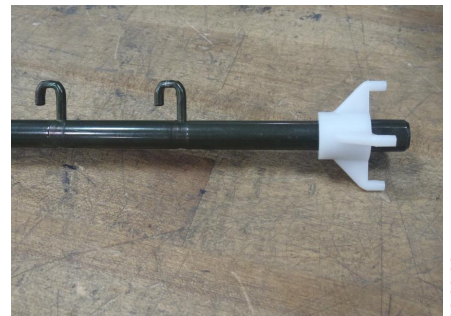

Figure 86

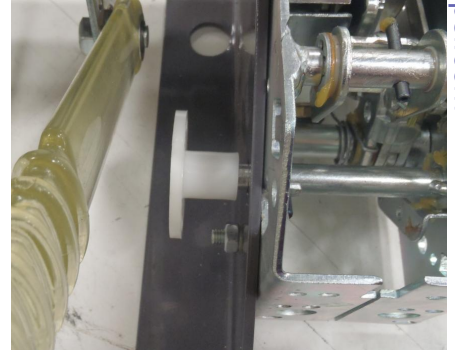
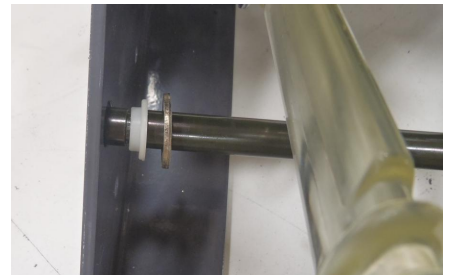

Figure 87



Installing the Top Mounted Fuse Base with Fuse Tripping

WARNING

These operations must be carried out by specialists only! Improper installation may result in serious injury or death.

Adjusting the fuse tripping:

Charge the A-mechanism as described below in “Fuse tripping control”.

1. Adjust the release shaft to a position so that the distance from fuse trip flap to fuse is within the limits of figure 90.
2. Secure the washer and bearing on the left side of the release shaft as shown in figure 88.
3. Secure the end of the release rod (11) to the release shaft (1) as shown in figure 89.

Notes:

1. Check distance between fuse trip flap and fuse to match that of figure 90 once installation is complete. Adjustments can be made at the release rod (11) and lever (13) connection point.

Fuse tripping control:

1. Turn the operating shaft of the mechanism a maximum of 60° clockwise and return the handle back to the neutral position (opening spring housing must not be latched).
2. Mount a new fuse-link, or test fuse in accordance with DIN 43625, in one of the phases.
3. If the distance between the fuse clips is longer than shown in figure 90, max e + 8 mm, the adjustment must be made with the fuse link resting on the fuse clips on the fuse base.
4. The distance between the striker pin and the fuse trip flag (15) must be between 3-6 mm. The fuse link is allowed to sag but the distance between the striker pin and fuse trip flag must not exceed 12 mm.
5. If the VersaRupter does not open when adjusted as mentioned above, the adjustment must be repeated.

Figure 88

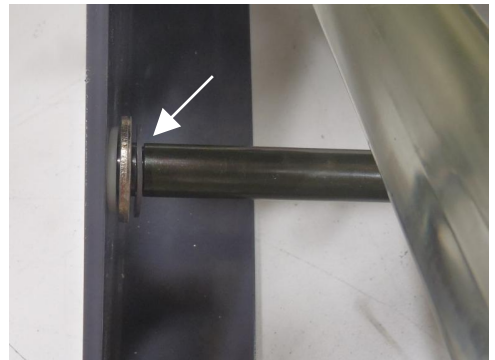

Figure 89

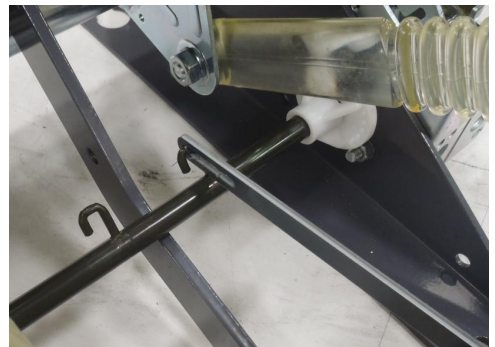
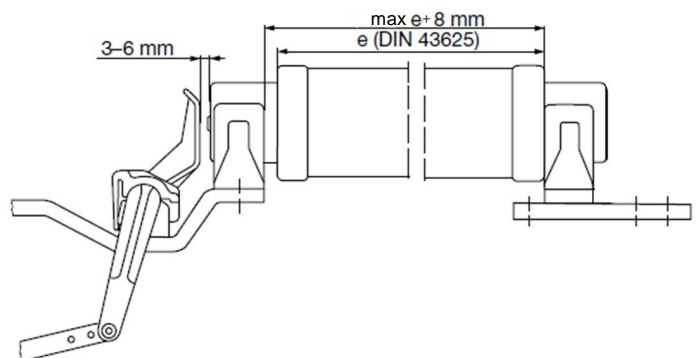

Figure 90



Mounting the HE/HM Operating Handles

The HE and HM operating handles include a bevel gear and front mount universal joint. The HE handle has an arrestor ring that must be pulled out as the removable handle is rotated to open or close the switch. The HM handle must be used if manual operation is desired with use of the NM motor operator. The HM handle does not have the arrestor ring.

Ensure the opening spring is not charged if an A-mechanism is installed.

1. Install the bevel gear onto the operating shaft of the mechanism or grounding switch. Easiest if done before the VersaRupter is installed into an enclosure. See figure 91 for proper orientation of the bevel gear.
2. Install the front mounted universal joint onto the enclosure using a 17 mm socket. Fabricate a 3/4" pipe to connect the bevel gear and front universal joint. The bolt holes should not exceed 10 mm.

For HE handles:

3. Remove the Seeger ring, spring and nut. See figure 92.
4. Slide the arrestor ring off of the splined shaft. See figure 93. The splined shaft should be free to rotate.
5. If paired with an A-mechanism, use the removable handle to charge the A-mechanism.
6. Test the installation by opening and closing the switch.
7. Slide the arrestor ring back onto the splined shaft.
8. Slightly pull the arrestor ring out so it clears the locking tab on the front universal joint.
9. Close the VersaRupter and ensure the front universal joint indicates the switch is closed as in figure 94.
10. If not, remove the arrestor ring and reinstall it positioned 2-3 teeth rotated to the right.
11. Once in the correct position, reinstall the spring, nut, and Seeger ring.

Figure 91

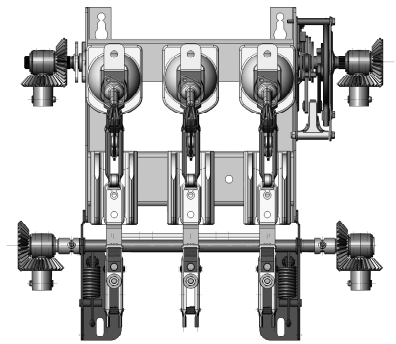

Figure 92



Figure 93



Figure 94



Installing the Chain Drive Handle

Refer to the drawing for “Chain Drive Assembly” .

1. Secure the sprocket to the operating shaft of the mechanism and secure it with the setscrew.
2. Bolt the chain drive housing to the switchgear enclosure using 4 3/8"-16 X 3/4" hex head bolts and 3/8" lock washers. If installing on the right hand side, install the angle bracket from the chain guard along with bolting on the chain drive housing. Reference drawing “Chain Drive Assembly” for details.
3. Ensure that the switch is closed and the handle is in the up position.
4. Bolt the angle from the chain guard to the angle bracket. Slide the angle assembly onto the sprocket and bolt it to the angle that was previously installed. The angle is slotted to allow for depth adjustment. The chain guard assembly is not required if chain drive is installed on the left hand side.
5. Install the chain onto the sprockets securing them with the turnbuckles and chain guard. If the switch is mounted upright, the chain must be crossed as shown in the referenced drawing. If the switch is inverted, the chain does not need to be crossed. Ensure that the turnbuckles are not closer than 6" to either sprocket while the switch is in the closed position with the handle up. Do not exceed a 1" misalignment within sprocket to sprocket plane.
6. Adjust the chain between the switch and handle until the top and bottom of the chain is snug. Open and close the switch 10 times using the handle and make final adjustments to the turnbuckles. If properly adjusted, the handle should be approximately 3/4" to 7/8" from the handle stop in either position when the switch trips.

Installing the Direct Drive Handle

Refer to the drawings "Direct Drive Handle Right Side/Left Side" for details.

1. Ensure that the VersaRupter is closed and the handle is in the closed position.
2. Mount the direct drive handle to the switchgear enclosure using a 9/16" socket making sure the hub assembly slides onto the operating shaft of the VersaRupter.
3. Check that the VersaRupter opens and closes when the handle is operated.

Installing the Back Connect Kit

These instructions apply for top and bottom mounting of the back connect insulated bus bars. Reference back connection kit outline drawings found towards end of manual to identify parts.

1. When mounting the back connect kit, first secure the brackets to the frame with the same bolts used to secure the VersaRupter frame to its enclosure.
2. Attach the standoff insulators to the brackets provided using 1/2" bolts.
3. Mount the insulated bus bars to the standoff insulators using one 3/8" bolt, a steel 3/8" washer, and two red washers.
4. Install the GPO-3 washers such that they are positioned on each side of the back connect bus bar to protect the bus bar insulation. The steel 3/8" washer should be between the GPO-3 washer and the head of the 3/8" bolt.
5. The back connect bus bar is attached to the VersaRupter terminals with the hardware provided with the VersaRupter. The back connect bus bars may be connected to cabling or bus work as needed. For dielectric purposes, bus boots may be installed at the termination of the back connect bus bar and the field connections.
6. Torque all hardware in accordance with standard torque guidelines per the bolt sizes.

Installing the K-mechanism



WARNING

These operations must be carried out by specialists only! Improper installation may result in serious injury or death.

Ensure that the VersaRupter is in the open position.

1. The jack shaft should appear as in figure 95 when looking at it from the right side, where the mechanism will be installed.
2. Place the mechanism up against the frame of the VersaRupter while sliding the jack shaft connection point in figure 96, into the jack shaft and the studs into the mounting holes of the frame. The jack shaft may need to be wiggled for the mechanism to engage.
3. Secure the mechanism with the provided loose bolt in figure 97, and the other two studs in figure 98. Tighten nuts to 25 Nm using a 13 mm socket.
4. Check that the mechanism properly opens and closes the VersaRupter.

Figure 95



Figure 96

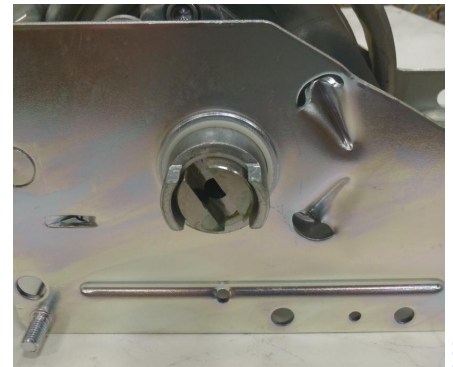

Figure 97

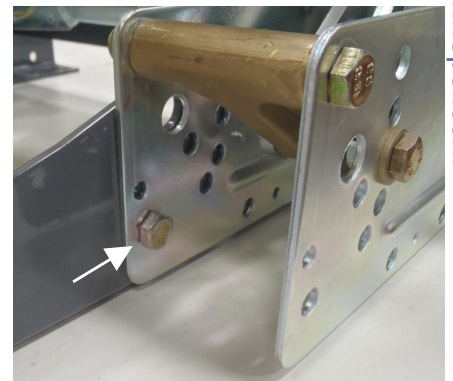

Figure 98



Installing the A-mechanism



WARNING

These operations must be carried out by specialists only! Improper installation may result in serious injury or death.

Ensure that the VersaRupter is in the open position.

1. The jack shaft should appear as in figure 99 when looking at it from the right side, where the mechanism will be installed.
2. Place the mechanism up against the frame of the VersaRupter while sliding the jack shaft connection point in figure 100, into the jack shaft and the studs into the mounting holes of the frame. The jack shaft may need to be wiggled for the mechanism to engage.
3. Secure the mechanism with the provided nuts and washers in figures 101 and 102. Tighten nuts to 25 Nm using a 13 mm socket.
4. Check that the mechanism properly opens and closes the VersaRupter.

Figure 99



Figure 100

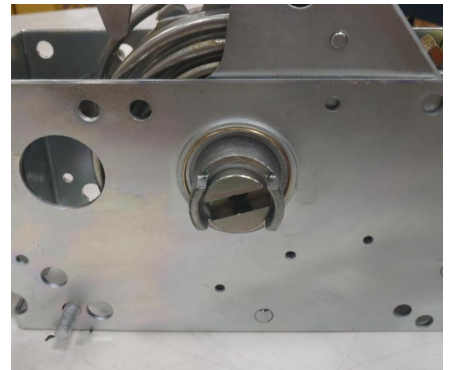

Figure 101

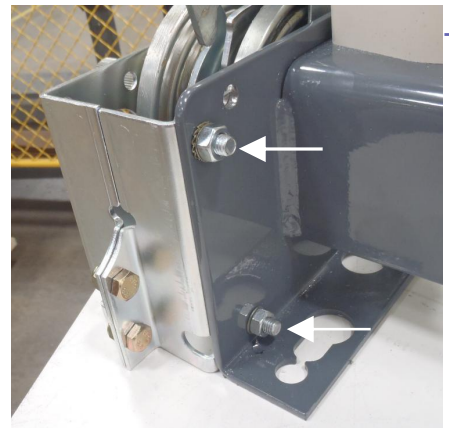
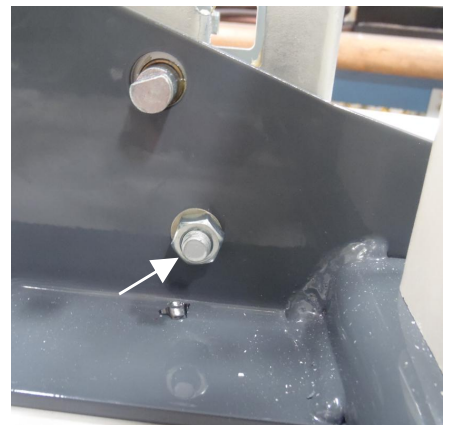
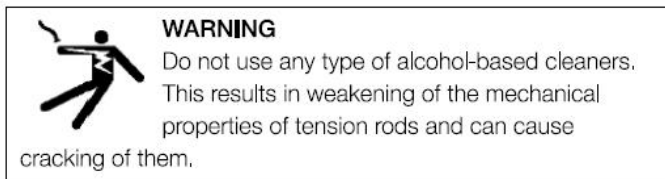

Figure 102



Service and Maintenance



Cleaning

After maintenance, the VersaRupter must be cleaned before being put into service. Strong solvents and alcoholic fluids must not be used. For cleaning, water with soap can be used. After cleaning, the contact area of the main blades and the fixed contacts must be greased with ISOFLEX TOPAS NCA 52. If the VersaRupter is placed in a very humid and polluted area, which will reduce the tracking resistance, it is recommended to polish the insulators and insulated components with Silicon Type DC200 Fluid 100 cst.

VersaRupters in Service

The VersaRupter should be checked at least once a year by conducting a number of operations to check all the functions. The frequency of maintenance depends on the service and environmental conditions.

- Moving and fixed contacts are greased with ISOFLEX TOPAS NCA 52.
- Mechanisms do not need any greasing under normal conditions.

Note!

Arcing knives, piston and cylinder must not be greased.

Mechanical overhaul

For new design "NAL New Design", maintenance can be done in 15 year intervals if the following service conditions are met:

1. VersaRupter must be transported and stored in a genuine box.
2. Installation service conditions:
 - a. VersaRupter must work in indoor application under normal service conditions according to IEEE C37.20.4.
 - b. VersaRupter must be installed by staff who have read this manual and installed according to manufacturer's recommendation.
 - c. Maximum number of mechanical cycles of 1000 must not be exceeded.
 - d. Maximum values and numbers of the making and breaking capacity must not be exceeded.

- e. Safe distanced to earthed parts or to other live parts must be kept.
- f. In special cases (fault in circuit where VersaRupter is installed or the apparatus will be overloaded) VersaRupter should be inspected.
- g. VersaRupter is not installed vertically with hollow insulators at the bottom which could cause condensation in the hollow insulators and arc extinguishing system.

Complete overhaul of the VersaRupter should be carried out after 1000 operations or 5 (15 for new switch versions) years in service, preferably by ABB's staff.

Electrical Overhaul

The frequency of overhaul depends on the number of operations and the magnitude of the breaking current. After about 100 operations at rated current or about 500 operations at half the rated current, the main contacts, the arcing contacts and the arc extinguishing chamber should be inspected and replaced if necessary.

Replacement should take place when:

- The tip of the arcing contact knives has diminished approximately 3 mm (minor damage might only cause polishing of the arcing tip).
- The fixed arcing fingers are burned or do not make any contact.
- The width of the slot in the arcing chamber is more than 8 mm.

If the copper is visible on any current carrying bus part, then this part should be replaced by a new one.

Service and Maintenance

WARNING

These operations must be carried out by specialists only! Improper installation may result in serious injury or death.

Control of the VersaRupter Knives after Mounting

Due to differences in the straightness of the wall and support frame, it is necessary to check the position of the main knives on the fixed contact.

1. VersaRupters with A-mechanisms are delivered with the draw bars (1.1) detached. Refer to figure 103.
 - a. Test that each arcing knife (1.2) moves freely in the arc chamber (1.3) by hand.
 - b. Pull the main contacts (1.4) by hand to open the VersaRupter. Attach the draw bars to the main shaft (1.5) near the eccentric bolt (1.6) and secure them with the washer and cir-clip.
2. VersaRupters with K-mechanisms are delivered with the draw bars connected.
3. Before operating the VersaRupter, check that the surfaces of the main contacts are covered by contact grease in the contact area. The grease type ISOFLEX TOPAS NCA 52 must be used if additional grease is required.
4. Close the VersaRupter by operating the mechanism. Check the engagement and the contact overlap. All four contact points on the main contacts must be in touch with the fixed contacts. The depth between the fixed and moving contacts must be adjusted by the eccentric bolt if the moving contact is outside of the 4 mm limit. See figure 105.

Figure 103

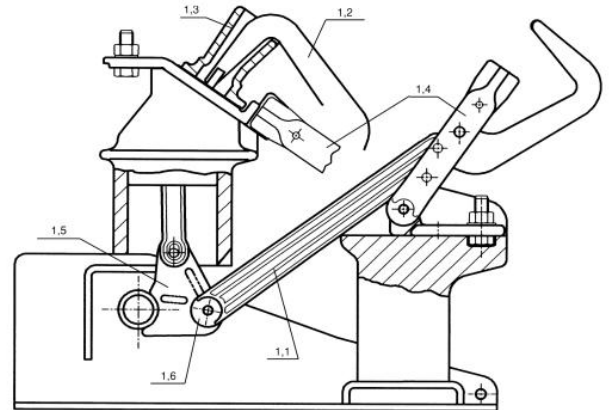

Figure 104

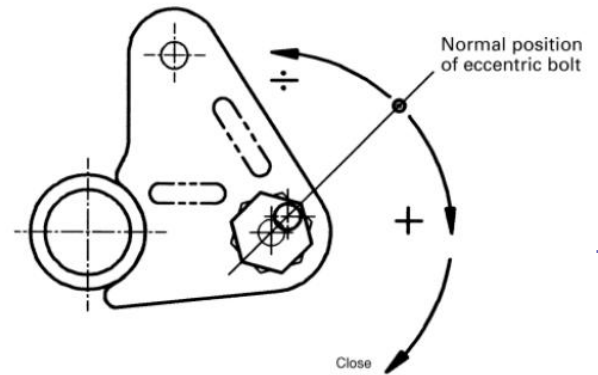
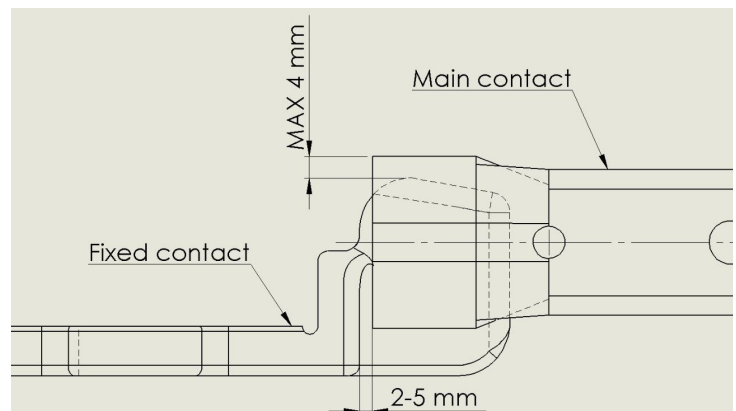

Figure 105



Replacement of Parts 5-27 kV

WARNING

These operations must be carried out by specialists only! Improper installation may result in serious injury or death.

The VersaRupter is equipped with DMC insulators (glass fiber-reinforced polyester) with self tapping screws to secure the insulators and contacts.

The following procedure must be followed if the same insulators and screws are to be used after replacing parts:

1. Unscrew the self tapping screws using a T40 Torx socket carefully and brush them clean. Blow out any small particles in the threaded holes with proper eye protection.
2. The screw must be reinstalled carefully into the threads of the insulator and tightened with care. See correct torque values in "Torque Values for Self Tapping Screws".

If a new insulator is being installed, the holes in the insulator should be threaded about 10 mm deep by the self tapping screw before mounting. Remove the screw and blow the threaded holes clean. See the procedures on the following pages regarding installation.

Figure 106

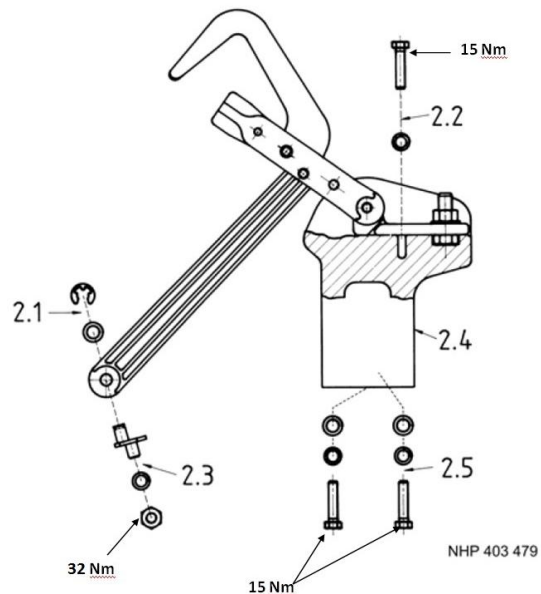
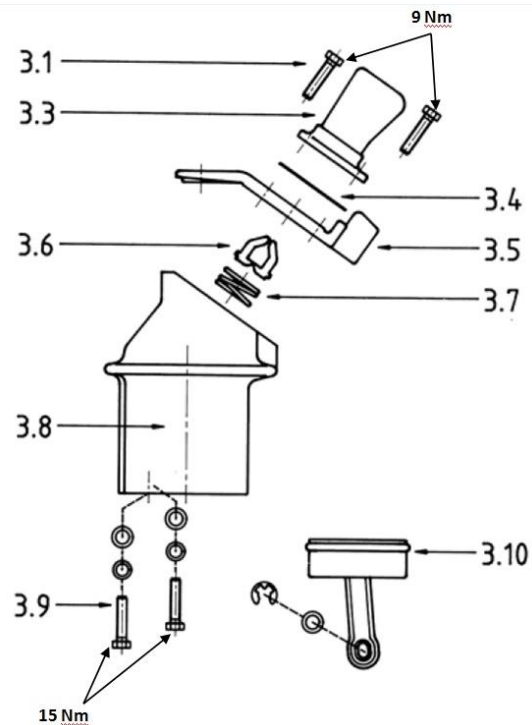

Figure 107



Replacement of Contact Knife with Draw Bar

WARNING

These operations must be carried out by specialists only! Improper installation may result in serious injury or death.

Ensure the VersaRupter is in the open position and both operating springs discharged.

1. Remove the cir-clip and washer (2.1) attaching the draw bar to the main shaft. Eccentric bolt does not have to be loosened. See figure 109.
2. Unscrew the screw(s) (2.2) attaching the main contact to the insulator using a T40 Torx socket, see figure 110. Remove the fixed contact with the contact knife and draw bar shown in figure 111.

Figure 108

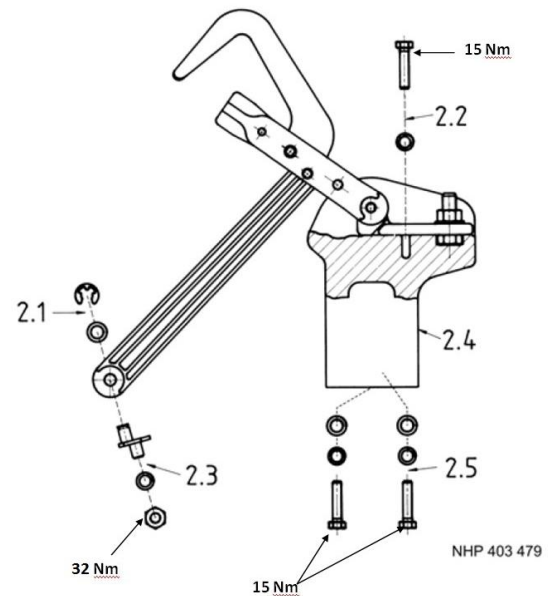

Figure 109

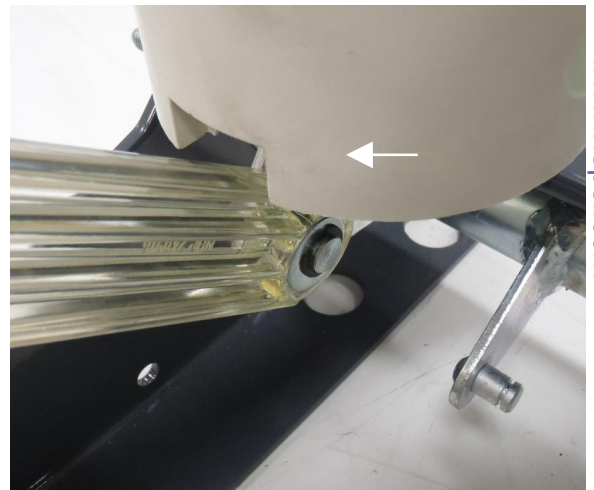

Figure 110



Replacement of Contact Knife with Draw Bar

3. Attach the new main contact with the contact knife and draw bar to the insulator as shown in figure 112.
4. Grease the new contact knife with ISOFLEX NCA 52 and check that it enters the fixed main contact correctly, and also that the arcing knife moves freely in the arcing chamber when closing and opening. The arcing knife does not have the same position related to the contact knife during the closing and opening movement. The contact knife must rotate firmly at the pivot point without jerking.
5. Attach the draw bar to the main shaft near the eccentric bolt (2.3) and secure with the washer and cir-clip (2.1).
6. The depth of the engagement between the fixed and the moving contact can be adjusted by the eccentric bolt (2.3), shown in figure 113, or by moving the insulator (2.4). Eccentric bolt should be torqued to 32 Nm.

Figure 111



Figure 112



Figure 113



Replacement of Fixed Contact and Arcing Chamber

Ensure the VersaRupter is in the open position and both operating springs discharged.

1. Using a T40 Torx socket, unscrew the two screw (3.1) and lift up the arcing chamber and the thermal disc (3.4 / 600 A) while pressing the main contact (3.5) firmly against the hollow insulator. See figure 115.
2. Lift up the main contact (3.5) by the arcing contacts (3.6) which penetrate the main contact. Remove the pressure spring (3.7) and clean the top of the insulator and the hole. Blow out the threaded holes. See figure 116.

Figure 114

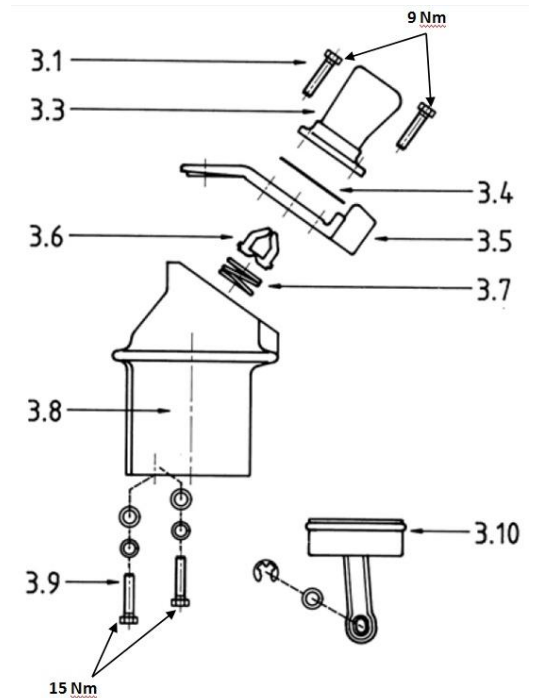

Figure 115



Figure 116



Replacement of Fixed Contact and Arcing Chamber

3. Replace the pressure spring back in the hole and place the contact onto the insulator making sure the cutouts in the arcing tips, see figure 117, are seated on the pressure spring.
4. Replace the thermal disc (600 A) and arc chute and screw the assembly down to secure it. See the correct torque values in the "Torque Values for Self Tapping Screws" section.

Note:

Damaged parts must be replaced.

The arcing contacts (3.6) must be seated correctly on the pressure spring (3.7).

When mounting the thermal disc (3.4) and the arcing chamber (3.3), the main contact (3.5) must be pressed firmly against the hollow insulator (3.8). Attach the whole assembly by screws (3.1). For correct torque values, see the "Torque Values for Self Tapping Screws" section.

Check correct position of the arcing contacts and test for correct functionality. Grease the contact area with ISOFLEX TOPAS NCA 52.

Figure 117

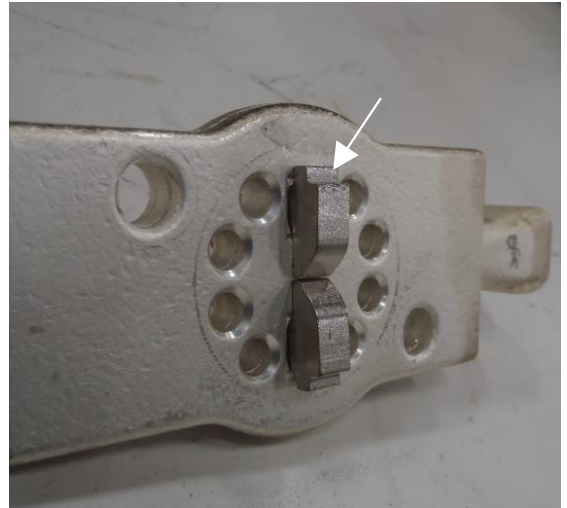

Figure 118



Figure 119



Replacement of Hollow Insulators with Arcing Chamber



WARNING

These operations must be carried out by specialists only! Improper installation may result in serious injury or death.

1. Using a T40 Torx socket, unscrew screws (3.9) and detach the insulator.
2. Attach the new insulator to the frame by the two self tapping screws (3.9)

Notes:

Remember to mount the piston with piston rod (3.10).

For correct torque values see the "Torque Values for Self Tapping Screws" section.

Do not forget to install the washer and spring washer for the self tapping screws.

Figure 120

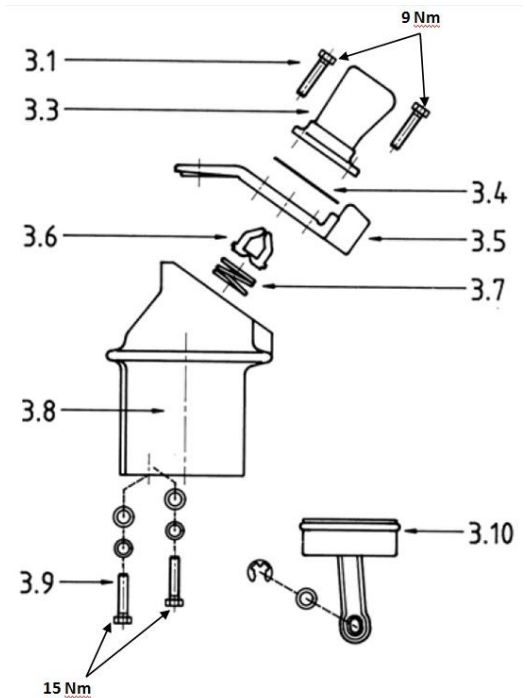

Replacement of Pivot Side Support Insulator

WARNING

These operations must be carried out by specialists only! Improper installation may result in serious injury or death.

1. Follow procedures from Replacement of Contact Knife with Draw Bar to remove the knife assembly.
2. Using a T40 Torx socket, unscrew screws (2.5) and detach the insulator.
3. Attach the new insulator to the frame by the two self tapping screws (2.5)
4. Attach the main contact with the contact knife to the top of the insulator and adjust according to procedures from "Replacement of Contact Knife with Draw Bar".

Notes:

For correct torque values see the "Torque Values for Self Tapping Screws" section.

Do not forget to install the washer and spring washer for the self tapping screws.

Figure 121

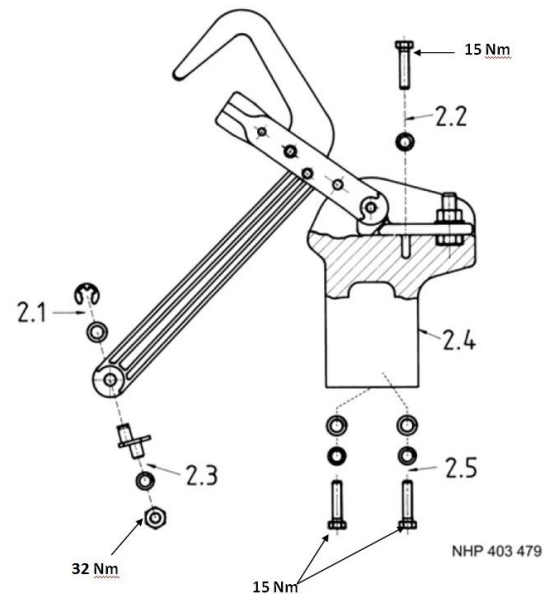

Replacement of Insulator on Fuse Base and Quick Make Earthing Switch

1. Using a T40 Torx socket, unscrew screws (4.2) and detach the fuse clips and contact blocks respectively.
2. Unscrew screws at the base (4.3) of the insulator and detach the insulator.
3. Attach the new insulator to the frame by the two self tapping screws (4.3).
4. Attach the fuse clips and contact block to the top of the insulator and secure with screws (4.2).

Figure 122

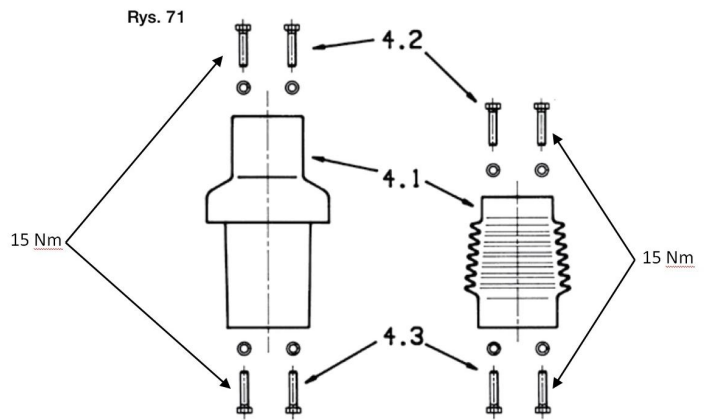

Replacement of Parts 38 kV



WARNING

These operations must be carried out by specialists only! Improper installation may result in serious injury or death.

Contact Knives

Ensure the VersaRupter is open and the A-mechanism is not charged (if equipped).

1. Detach the draw bar from the jack shaft by removing the cir-clip and washer as shown in figure 123.
2. Remove the contact screw found in figure 124 allowing the contact knives to be removed.
3. Lubricate the new contact blades with ISOFLEX TOPAS NCA 52 and attach them back to the lower terminal with the contact screw from the previous step.
4. Ensure that the contact knives can easily move and operate while making connection with the stationary contacts when closing.
5. Check the alignment of the arc blades when entering the arc chute.
6. Connect the draw bar to the jack shaft and secure it with a cir-clip.
7. Put contact grease on the main contacts before testing. The contact position is adjusted by the eccentric bolt on the operating shaft. It can also be adjusted by moving the lower insulator.

Figure 123

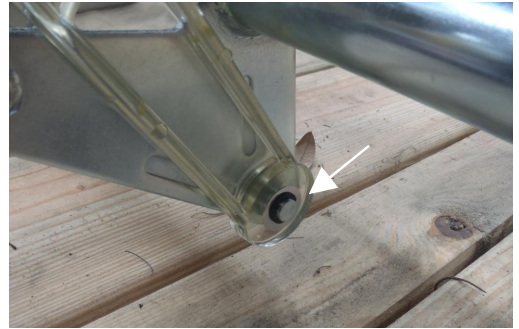
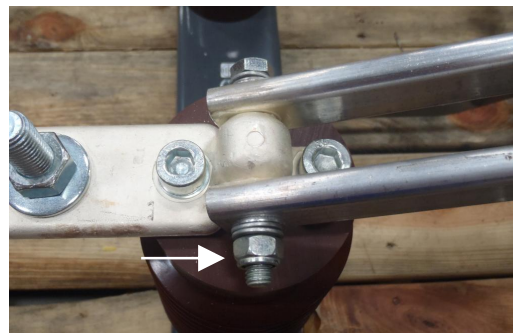

Figure 124



Replacement of Parts 38 kV

Draw bars

Ensure the VersaRupter is open and the A-mechanism is not charged (if equipped).

1. Remove the bolt found in figure 125.
2. Push the top of the arcing blade such that the draw bar bolt in figure 126 will be exposed and can be pushed out, freeing the upper end of the draw bar.
3. Remove the lower end of the drawbar by removing the cir-clip securing the draw bar to the jack shaft in figure 127.
4. Reinstall the new draw bar by attaching the upper part of the draw bar first, then the lower.

Figure 125

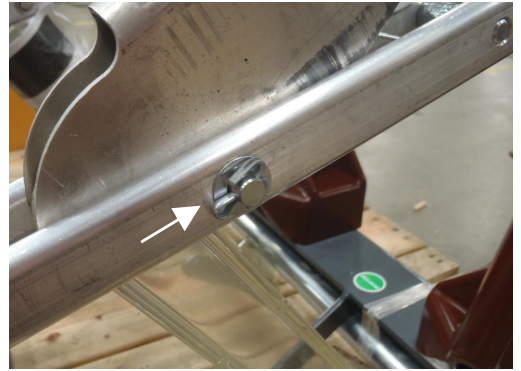
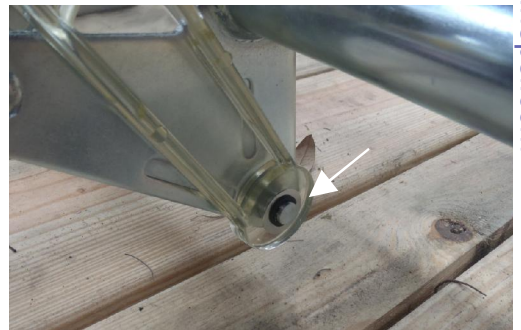

Figure 126



Figure 127



Replacement of Parts 38 kV

WARNING

These operations must be carried out by specialists only! Improper installation may result in serious injury or death.

Replacing the lower insulator

Ensure the VersaRupter is open and the A-mechanism is not charged (if equipped).

1. Remove the contact, item 2 in figure 128, from the lower insulator.
2. The insulator can be removed by unscrewing bolt 3 in figure 128.
3. Screw the new insulator back onto the frame with bolt 3.
4. Replace the contact, item 2, with the bolts removed from step 1.
5. Ensure the contact blades align properly.

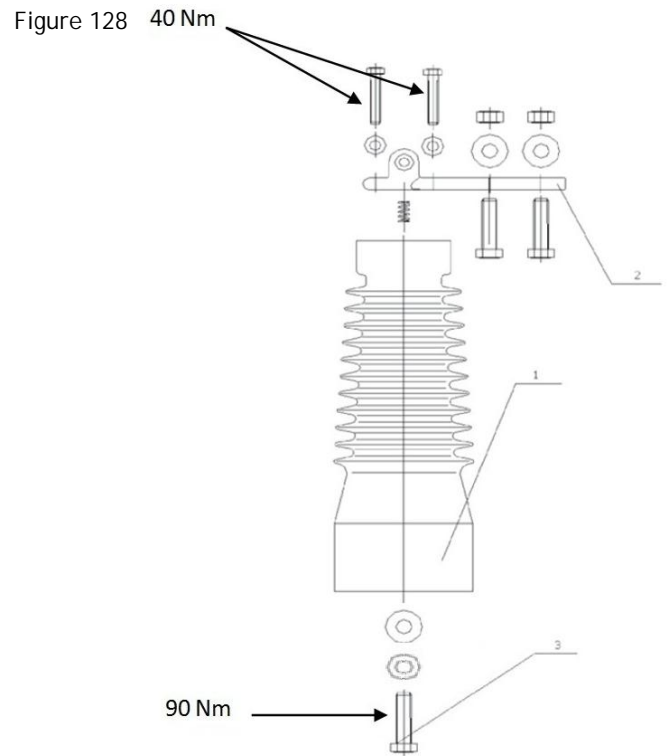

Replacement of Parts 38 kV



WARNING

These operations must be carried out by specialists only! Improper installation may result in serious injury or death.

Replacing the upper insulator

Ensure the VersaRupter is open and remove the operating mechanism from the VersaRupter.

1. Detach all of the draw bars from the jack shaft.
2. Rotate the jack shaft as if the switch was closing.
3. Disconnect the piston rod from the jackshaft by removing the cir-clip.
4. Remove the screws, item 3 in figure 129, to remove the upper insulator.
5. If contact blocks and arc extinguishing chambers are to be used again, they must be installed on the new upper insulator before the insulator is installed on the frame.
6. Replace the operating mechanism and attach all the drawbars and pistons to the jackshaft with cir-clips.
7. Check the alignment of the contact and arcing blades. Adjustments can be made by moving the upper insulator.

Figure 129

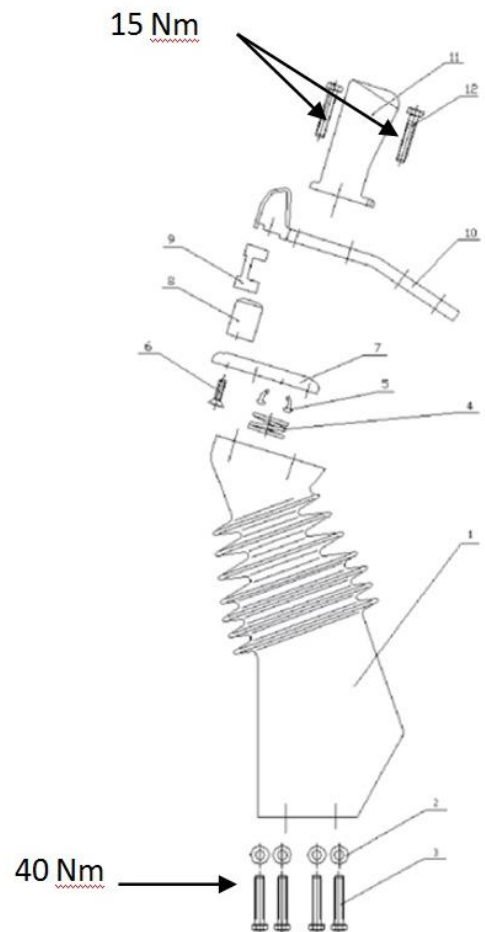

Replacement of Parts 38 kV

Changing the piston

Ensure the VersaRupter is closed and remove the operating mechanism from the VersaRupter.

1. Disconnect the lower part of the draw bar from the jackshaft by removing the cir-clip in figure 130.
2. Disconnect the piston rod from the jackshaft by removing the cir-clip, figure 131, and the piston can be removed.
3. Insert the new piston into the insulator and connect it to the draw bar with a cir-clip.
4. Do not grease or lubricate the new piston or cylinder!
5. Connect the lower part of the draw bar back onto the jack shaft with a cir-clip.

Figure 130

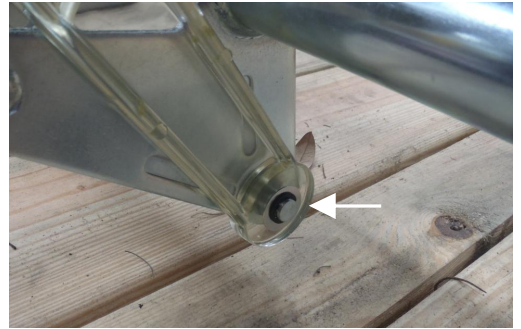
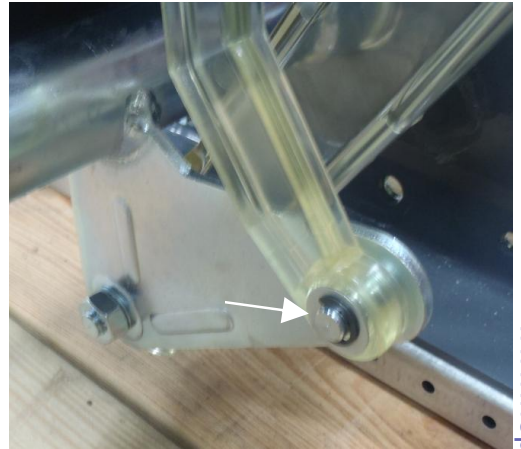

Figure 131



Torque Values for Self Tapping Screws

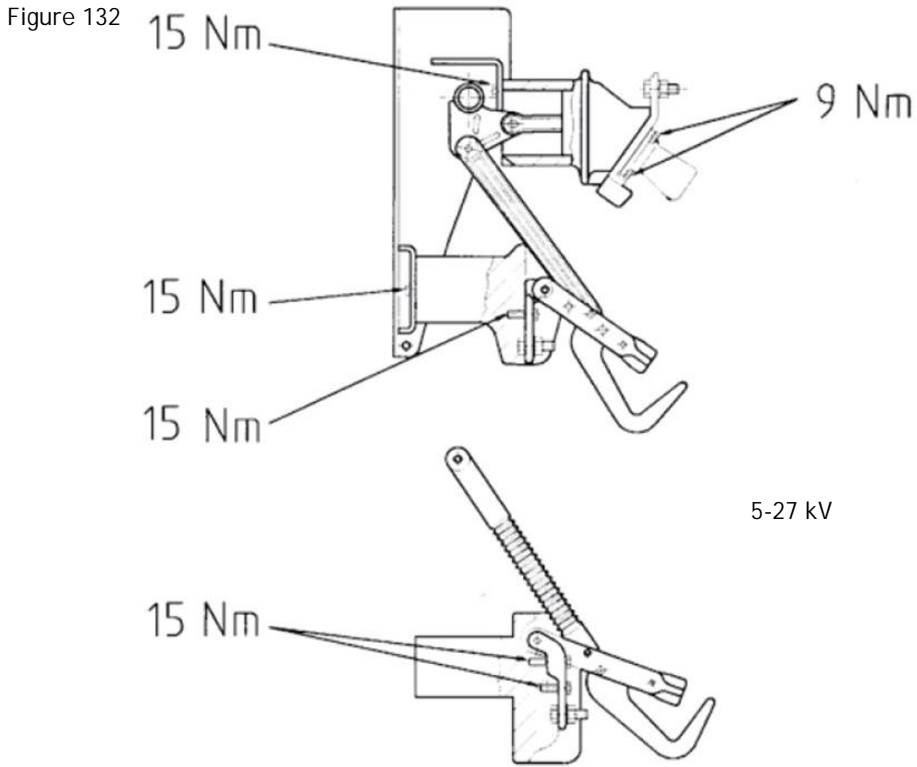
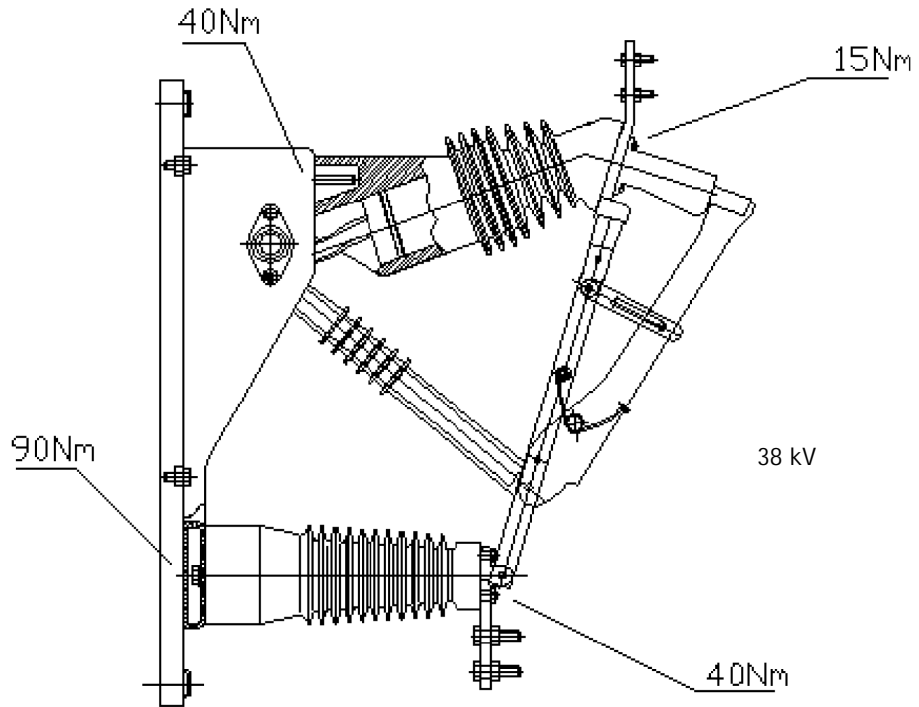
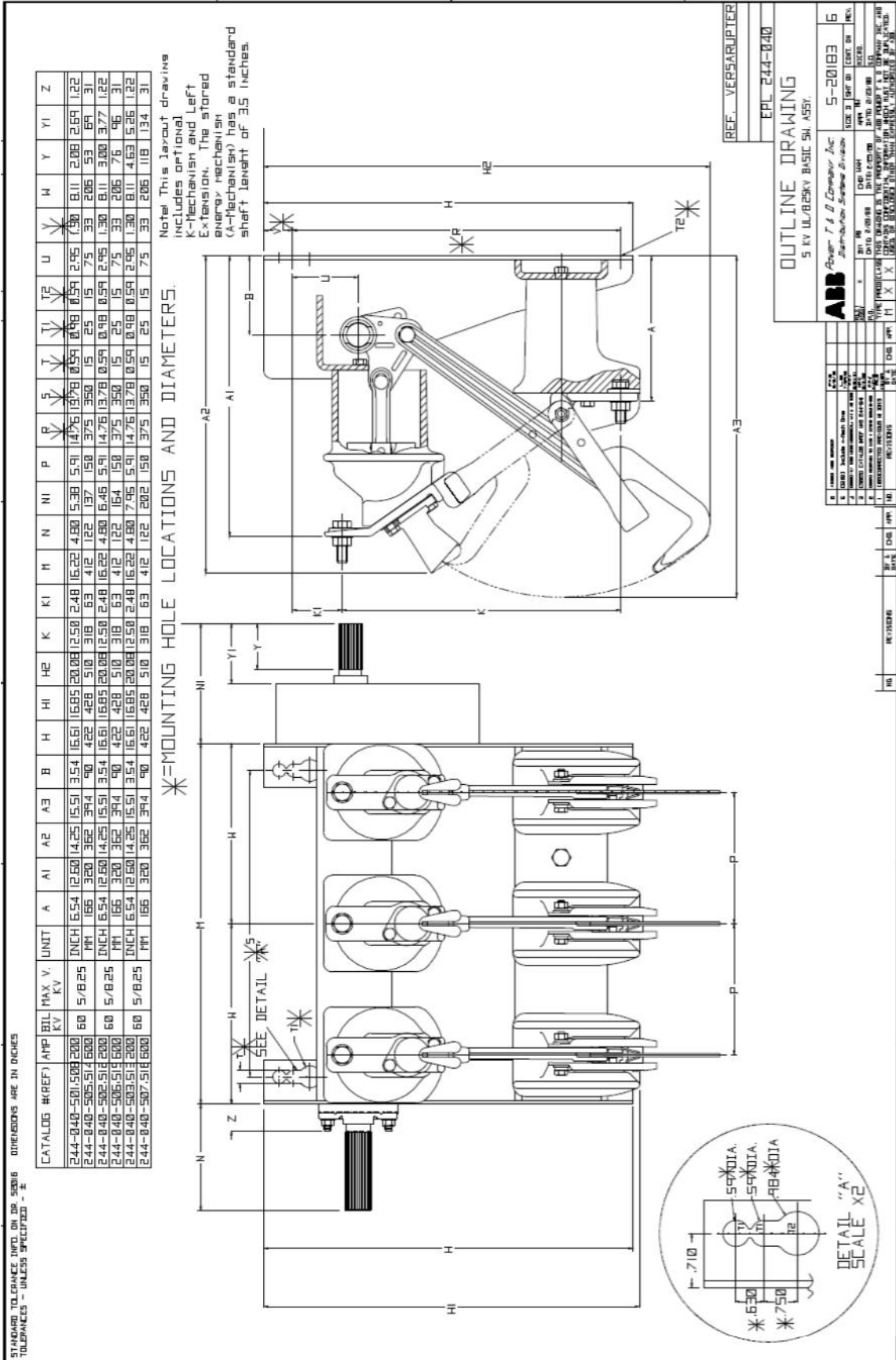

Figure 133



Outline Drawing

8.25 kV : 200/600 A : 40 kA



Outline Drawing

8.25 kV : 1200 A : 40 kA

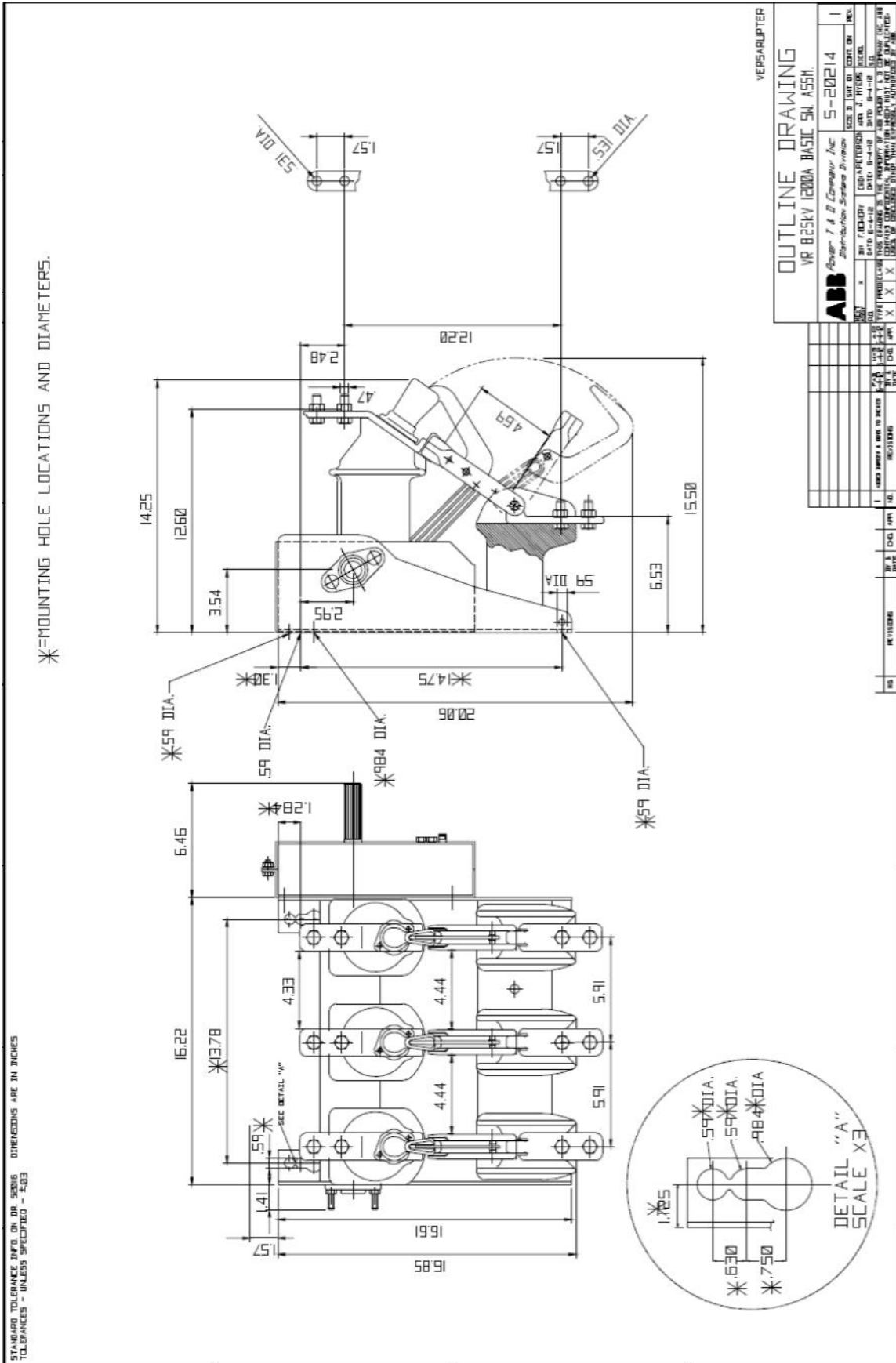

Outline Drawing

15 kV : 200/600 A : 40 KA

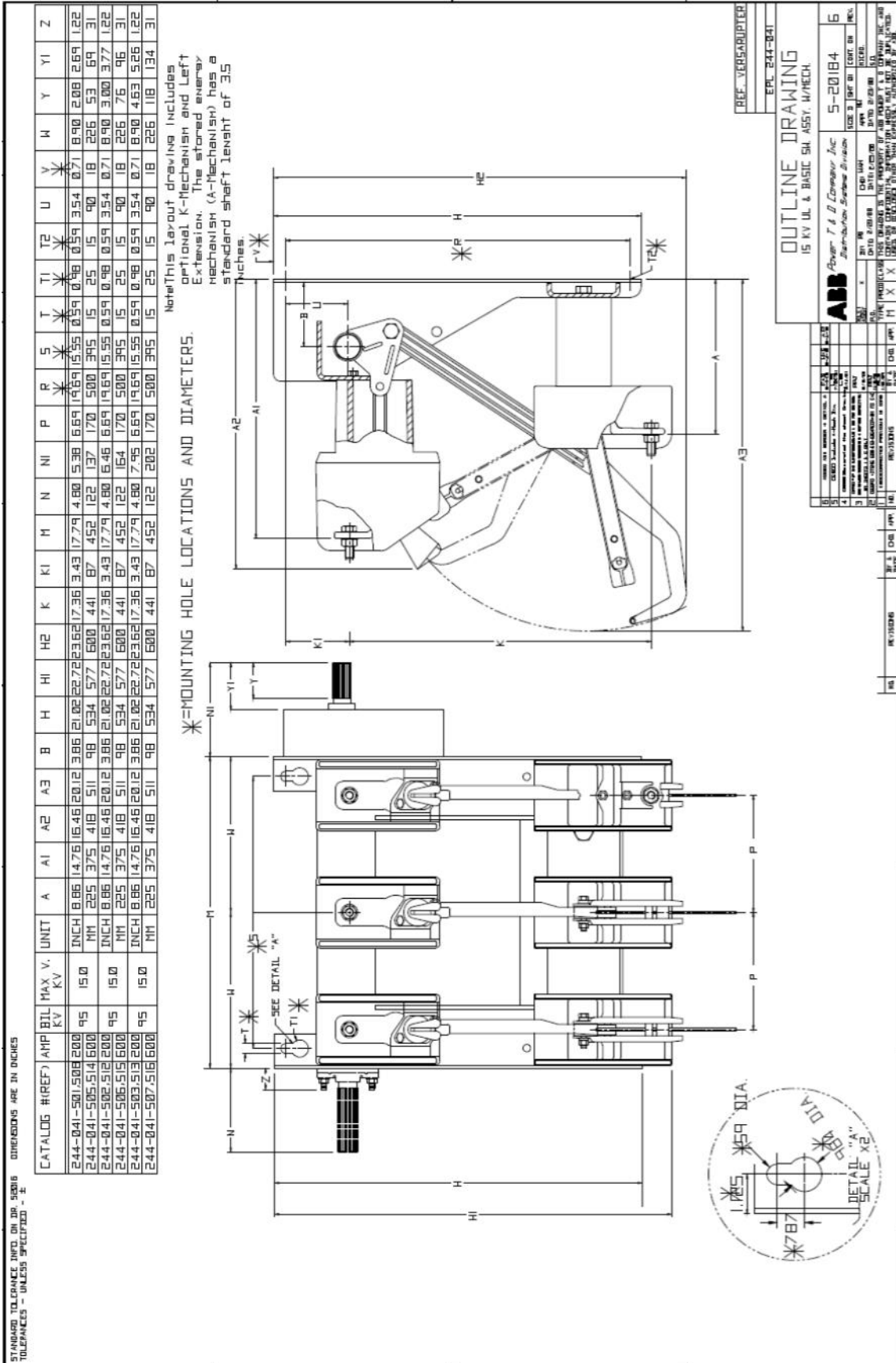

Outline Drawing

15 kV : 1200 A : 40 kA

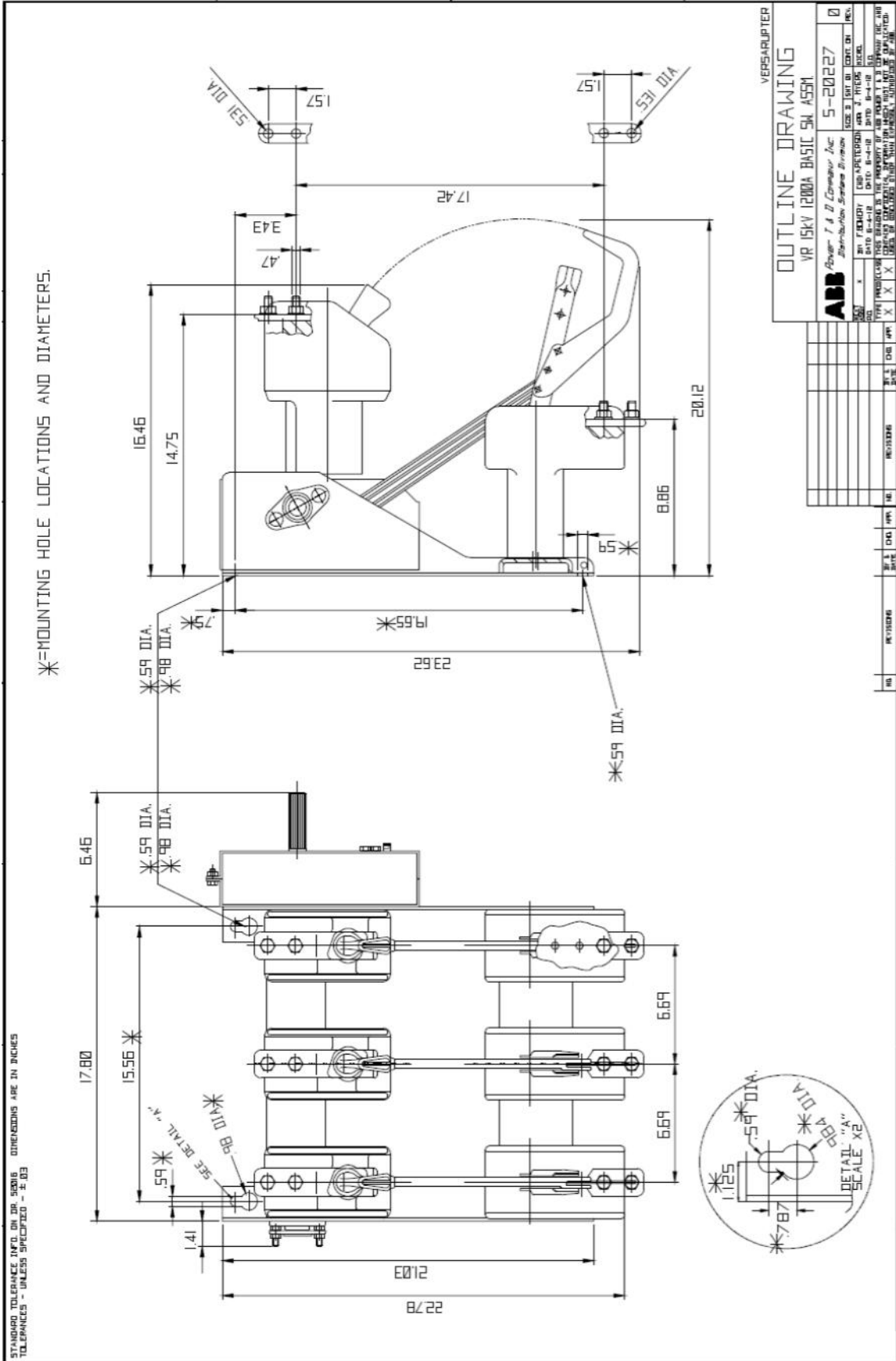

Outline Drawing

15/15.5 kV : 600/1200 A : 61 KA

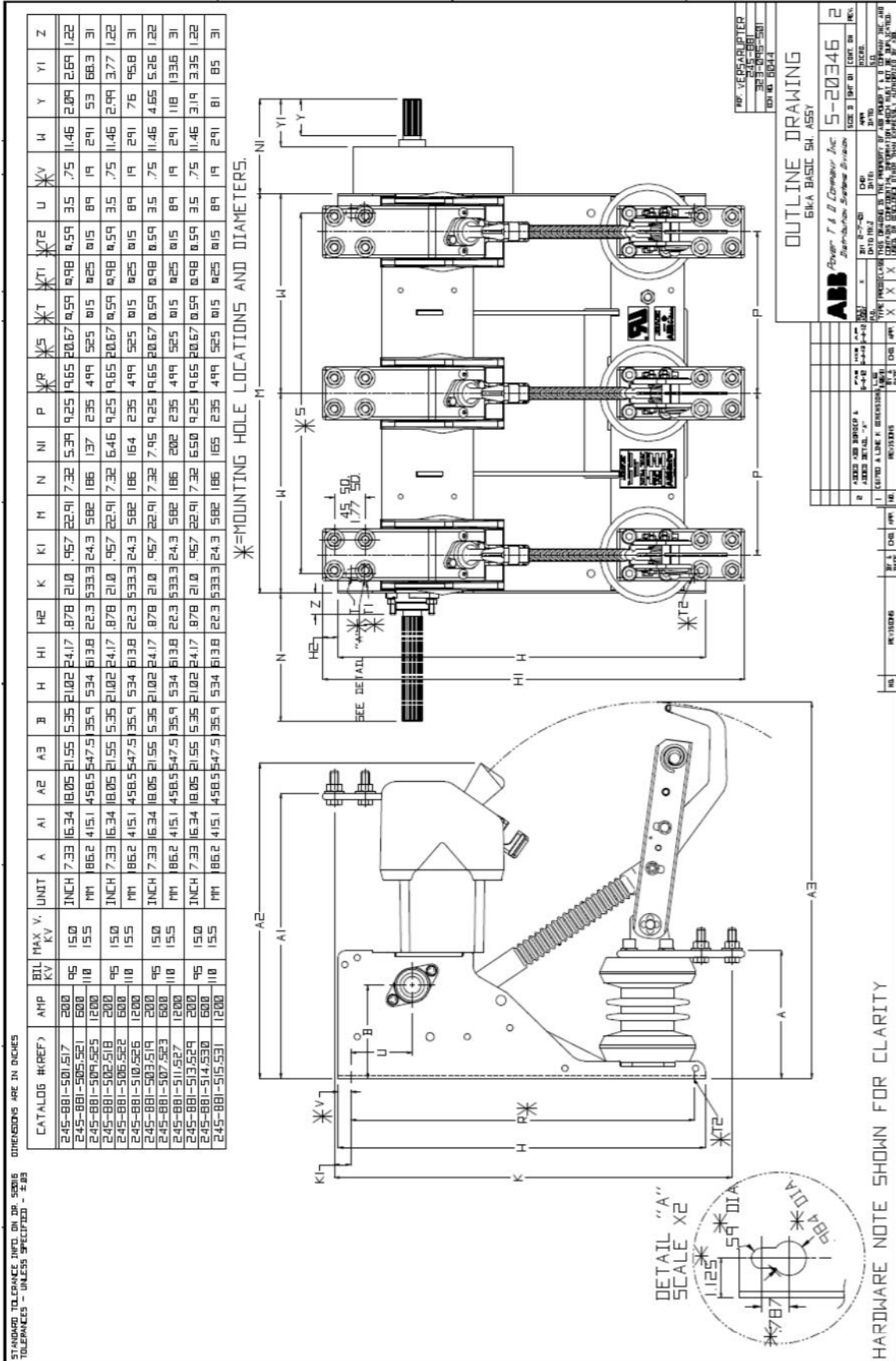

Outline Drawing

17 kV : 200/600 A : 40 KA

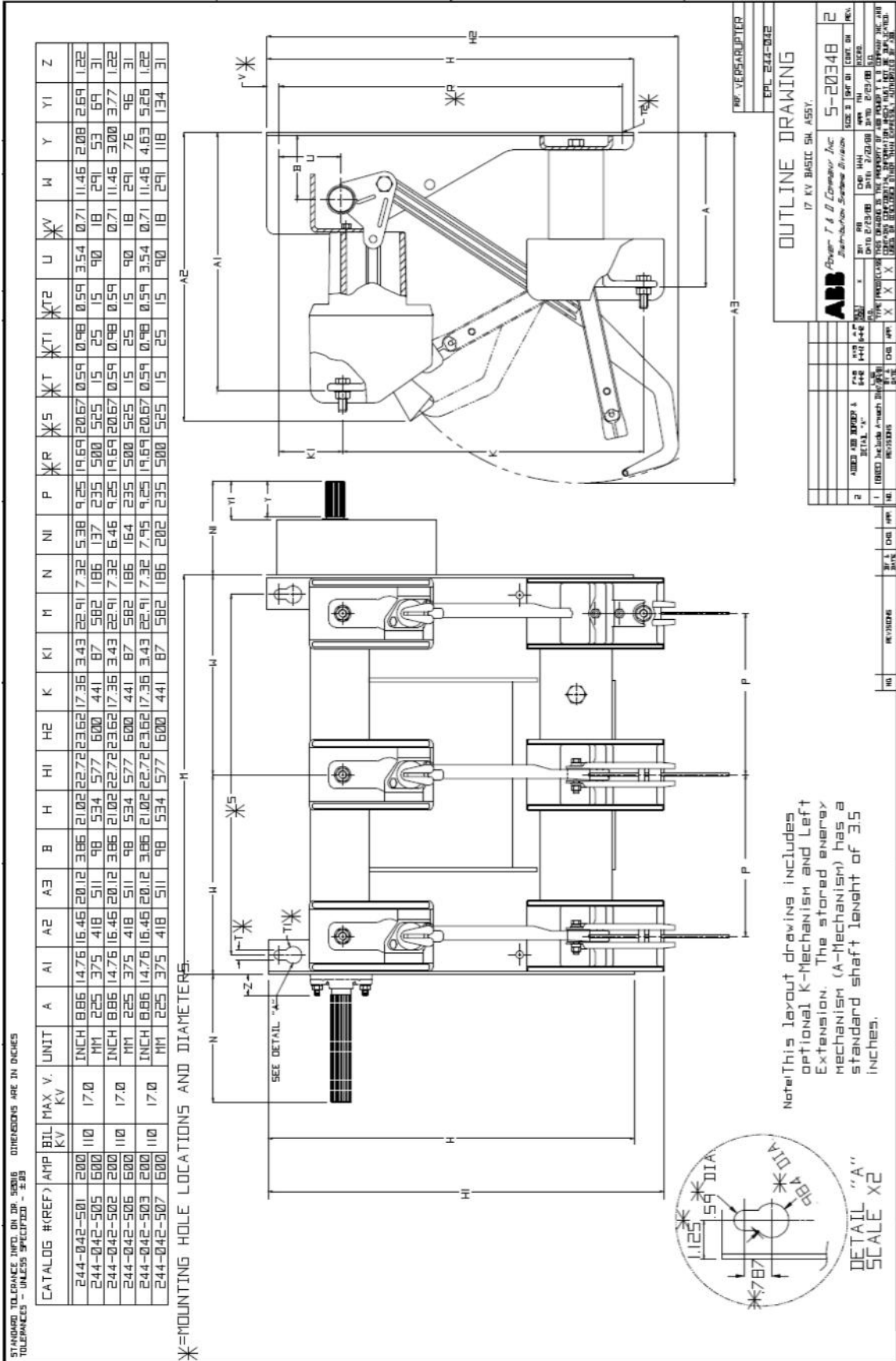

Outline Drawing

17 kV : 1200 A : 40 kA

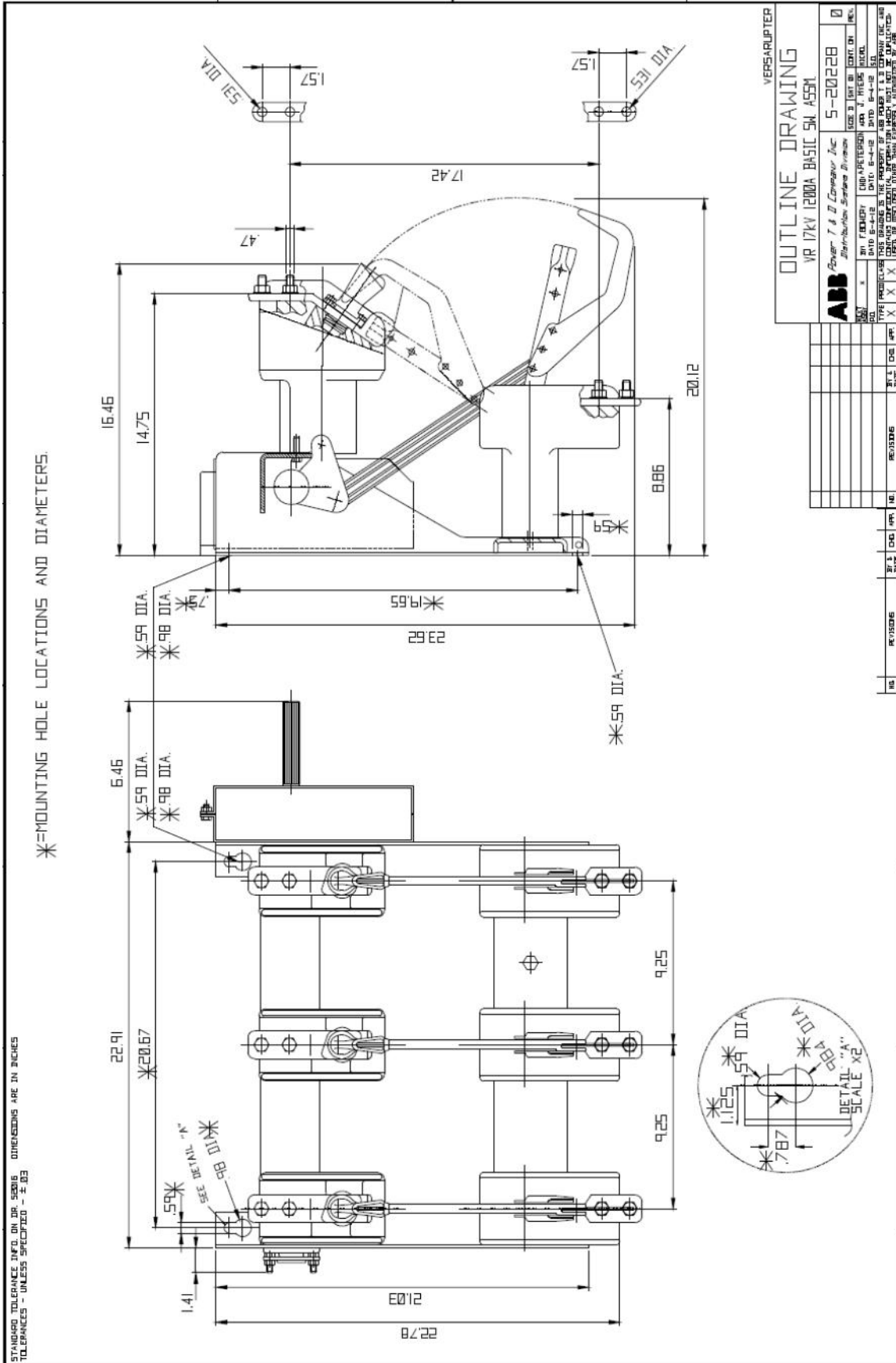

Outline Drawing

27 kV : 200/600 A : 40 KA

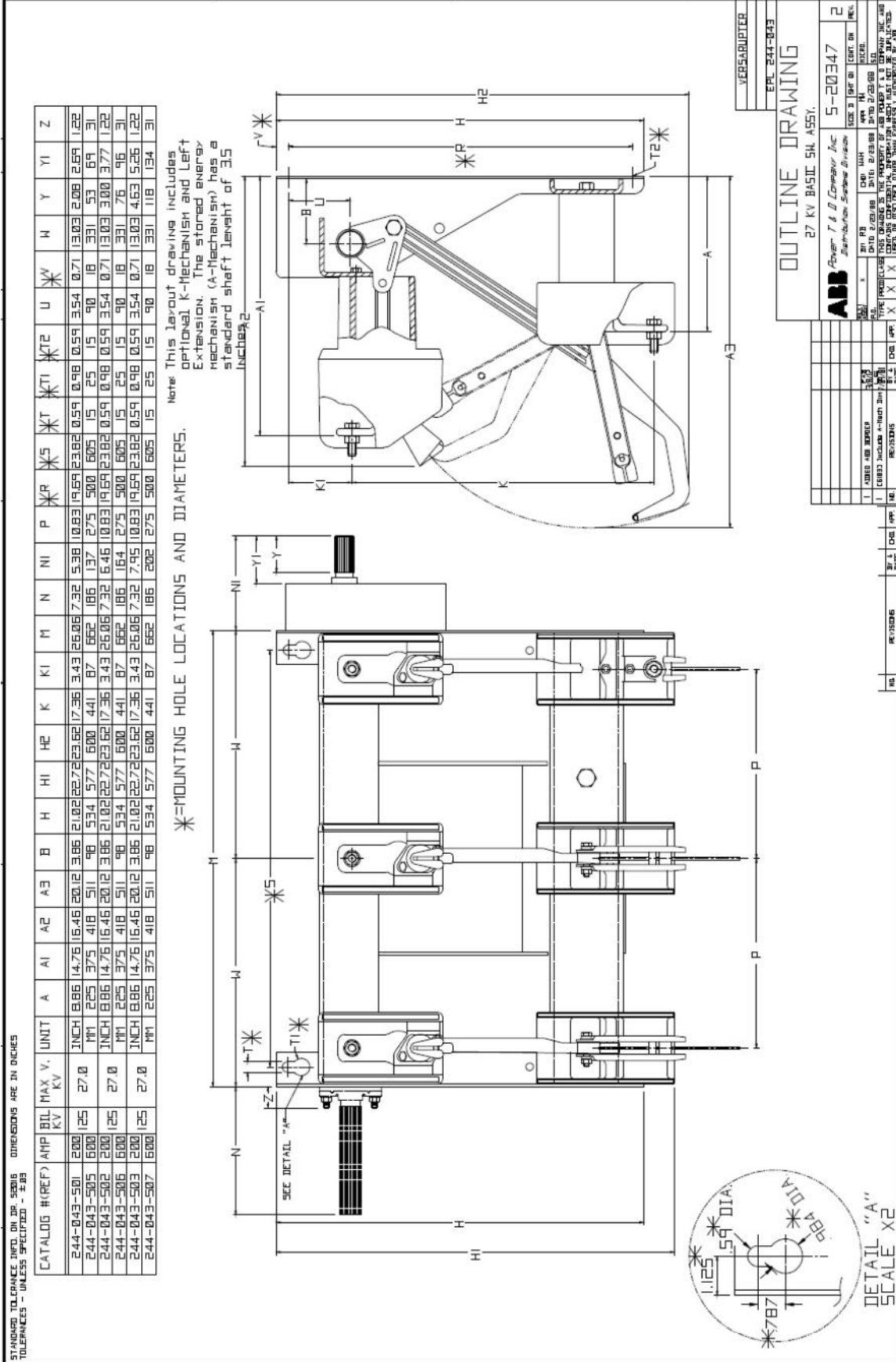

Outline Drawing

27 kV : 1200 A : 40 kA

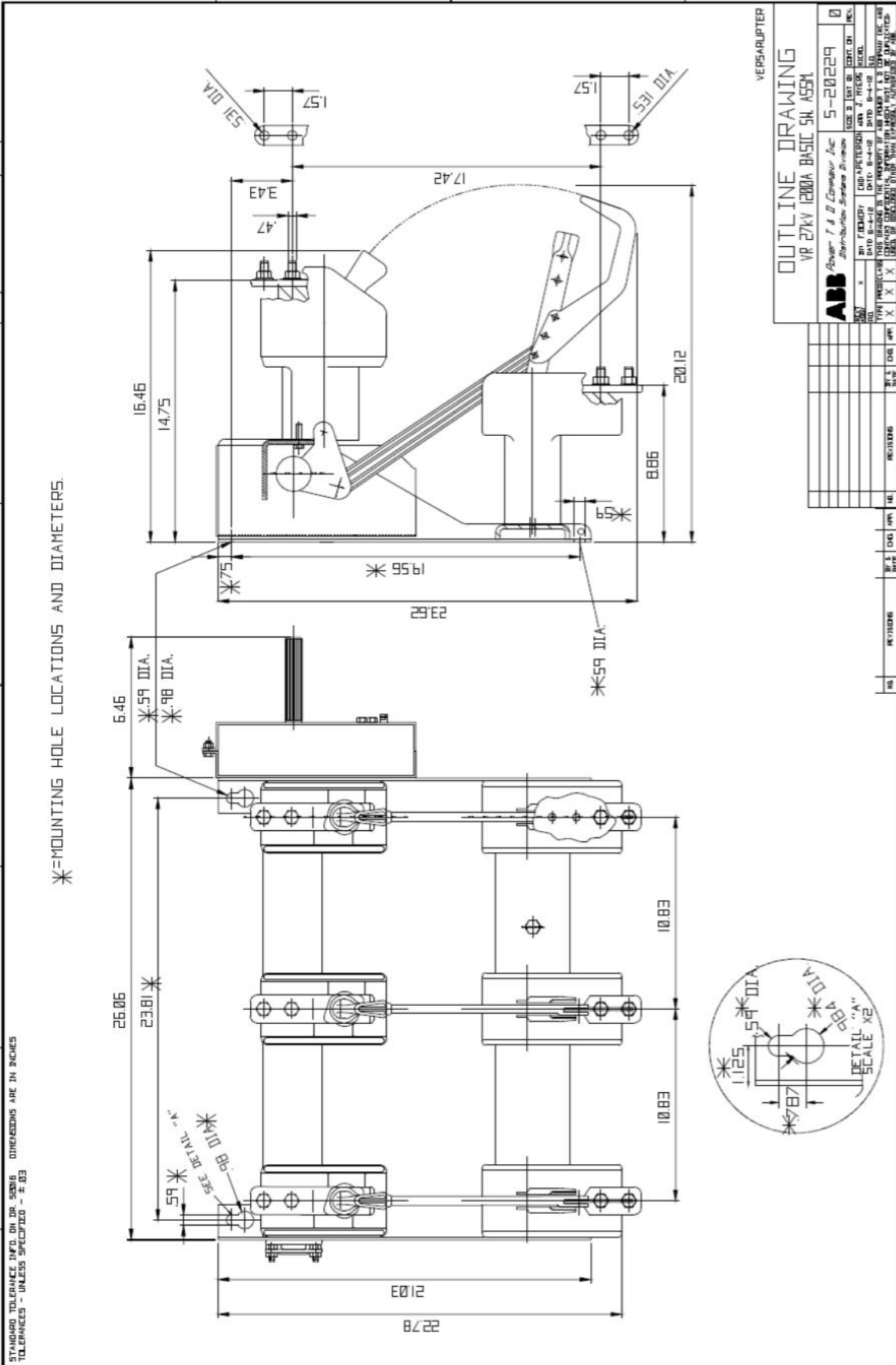

Outline Drawing

38 kV : 600/800 A

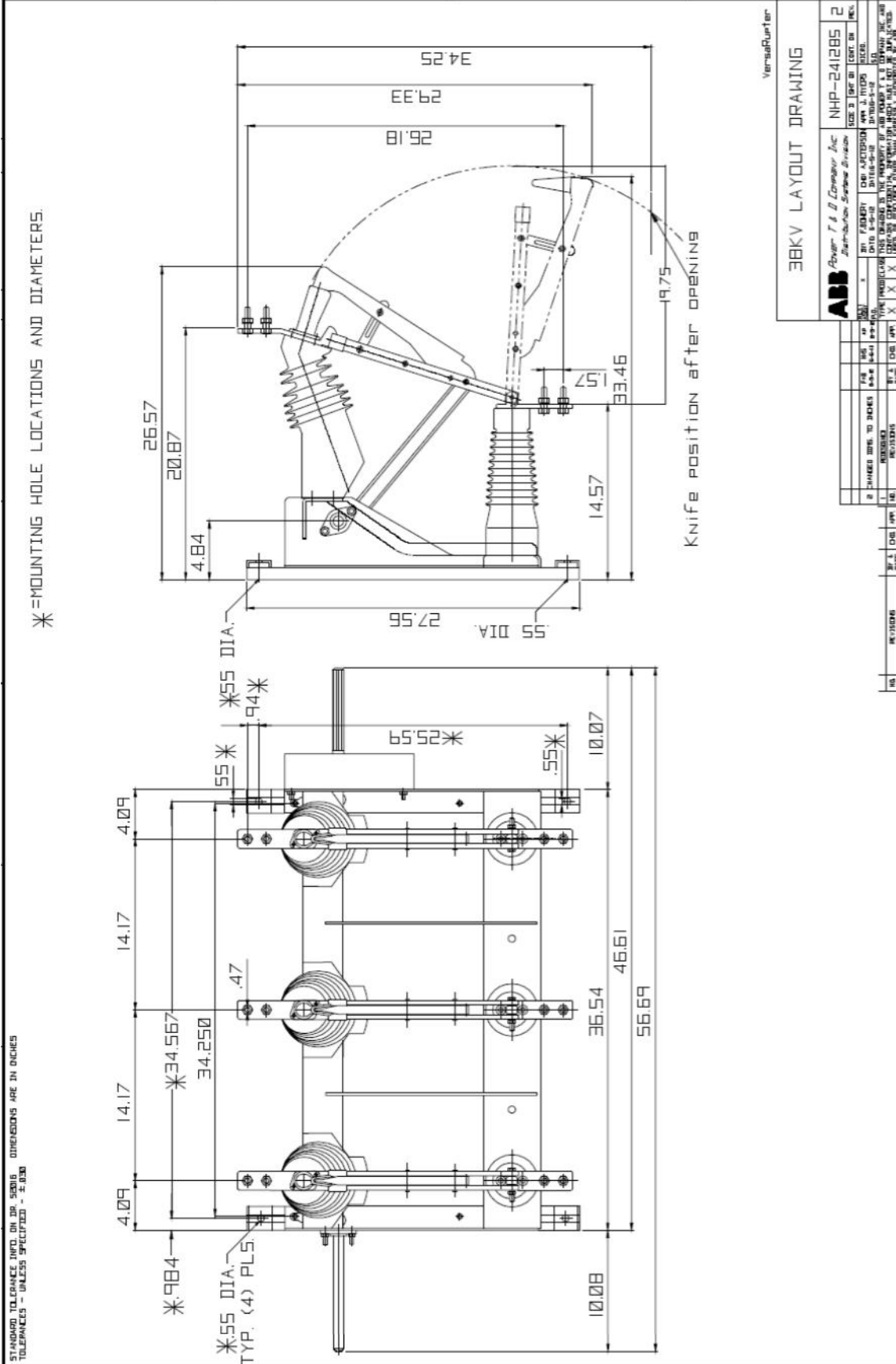

Back Connect Kit

5 kV : 200 / 600 A : 40 kA

STANDARD TOLERANCE UNLESS OTHERWISE SPECIFIED - UNLESS SPECIFIED - ±.005
DIMENSIONS ARE IN INCHES

ITEM	QTY	ITEM PART NO.	DESCRIPTION
1	1	244-094-001	UPPER BUS BRACE
2	3	244095-K01	UPPER BUS
3	3	244096-K01	LOWER BUS
4	3	245-907-001	STANDOFF INSULATOR
5	6	54398-C06	3/8-16 150" LONG BOLT
6	6	54500-H00	3/8" WASHER
7	3	54398-D02	1/2-13 .63" LONG BOLT
8	3	54500-100	1/2" WASHER
9	6	245-900-001	SPACER
10	6	245-899-001	WASHER

ABB Power T & D Company, Inc.
Distribution Service Division

BACK CONNECT KIT
5 KVVERSARUPTER

245-901 2

DATE: 11/10/10
DRAWN BY: J. J. JONES
CHECKED BY: J. J. JONES
APPROVED BY: J. J. JONES
SCALE: 1:1
SHEET NO. 1 OF 1

Back Connect Kit

15 kV : 200 / 600 A : 40 kA

STANDARD TOLERANCE INFO. ON DR. SPEC. DIMENSIONS ARE IN INCHES
TOLERANCES - UNLESS SPECIFIED - ±.03

QTY	ITEM	PART NO.	DESCRIPTION
1	1	245-097-001	UPPER BUS BRACE
3	2	245098-K01	UPPER BUS
3	3	245094-K01	LOWER BUS
3	4	245-907-002	STANDOFF INSULATOR
6	5	54390-C06	3/8"-16 1.50" LONG BOLT
6	6	54500-H00	3/8" WASHER
3	7	54390-D02	1/2"-13 63" LONG BOLT
3	8	54500-T00	1/2" WASHER
6	9	245-900-001	SPACER
6	10	245-899-001	WASHER

ABB Power T & D Company, Inc.
Distribution Services Division

BACK CONNECT KIT
15 KV VERSARUPTER

245-902 2

REV. 10/10/06

REVISIONS

NO. DATE BY APP. NO.

1 10/10/06 JMM/STP

2 10/10/06 JMM/STP

3 10/10/06 JMM/STP

4 10/10/06 JMM/STP

5 10/10/06 JMM/STP

6 10/10/06 JMM/STP

7 10/10/06 JMM/STP

8 10/10/06 JMM/STP

9 10/10/06 JMM/STP

10 10/10/06 JMM/STP

11 10/10/06 JMM/STP

12 10/10/06 JMM/STP

13 10/10/06 JMM/STP

14 10/10/06 JMM/STP

15 10/10/06 JMM/STP

16 10/10/06 JMM/STP

17 10/10/06 JMM/STP

18 10/10/06 JMM/STP

19 10/10/06 JMM/STP

20 10/10/06 JMM/STP

21 10/10/06 JMM/STP

22 10/10/06 JMM/STP

23 10/10/06 JMM/STP

24 10/10/06 JMM/STP

25 10/10/06 JMM/STP

26 10/10/06 JMM/STP

27 10/10/06 JMM/STP

28 10/10/06 JMM/STP

29 10/10/06 JMM/STP

30 10/10/06 JMM/STP

31 10/10/06 JMM/STP

32 10/10/06 JMM/STP

33 10/10/06 JMM/STP

34 10/10/06 JMM/STP

35 10/10/06 JMM/STP

36 10/10/06 JMM/STP

37 10/10/06 JMM/STP

38 10/10/06 JMM/STP

39 10/10/06 JMM/STP

40 10/10/06 JMM/STP

41 10/10/06 JMM/STP

42 10/10/06 JMM/STP

43 10/10/06 JMM/STP

44 10/10/06 JMM/STP

45 10/10/06 JMM/STP

46 10/10/06 JMM/STP

47 10/10/06 JMM/STP

48 10/10/06 JMM/STP

49 10/10/06 JMM/STP

50 10/10/06 JMM/STP

51 10/10/06 JMM/STP

52 10/10/06 JMM/STP

53 10/10/06 JMM/STP

54 10/10/06 JMM/STP

55 10/10/06 JMM/STP

56 10/10/06 JMM/STP

57 10/10/06 JMM/STP

58 10/10/06 JMM/STP

59 10/10/06 JMM/STP

60 10/10/06 JMM/STP

61 10/10/06 JMM/STP

62 10/10/06 JMM/STP

63 10/10/06 JMM/STP

64 10/10/06 JMM/STP

65 10/10/06 JMM/STP

66 10/10/06 JMM/STP

67 10/10/06 JMM/STP

68 10/10/06 JMM/STP

69 10/10/06 JMM/STP

70 10/10/06 JMM/STP

71 10/10/06 JMM/STP

72 10/10/06 JMM/STP

73 10/10/06 JMM/STP

74 10/10/06 JMM/STP

75 10/10/06 JMM/STP

76 10/10/06 JMM/STP

77 10/10/06 JMM/STP

78 10/10/06 JMM/STP

79 10/10/06 JMM/STP

80 10/10/06 JMM/STP

81 10/10/06 JMM/STP

82 10/10/06 JMM/STP

83 10/10/06 JMM/STP

84 10/10/06 JMM/STP

85 10/10/06 JMM/STP

86 10/10/06 JMM/STP

87 10/10/06 JMM/STP

88 10/10/06 JMM/STP

89 10/10/06 JMM/STP

90 10/10/06 JMM/STP

91 10/10/06 JMM/STP

92 10/10/06 JMM/STP

93 10/10/06 JMM/STP

94 10/10/06 JMM/STP

95 10/10/06 JMM/STP

96 10/10/06 JMM/STP

97 10/10/06 JMM/STP

98 10/10/06 JMM/STP

99 10/10/06 JMM/STP

100 10/10/06 JMM/STP

Back Connect Kit

17 kV : 200 / 600 A : 40 kA

QTY	ITEM PART No.	DESCRIPTION
1	245-805-001	UPPER ILS BRACE
1	245-806-101	UPPER ILS
3	245-807-101	UPPER ILS
3	245-808-101	UPPER ILS
3	245-809-101	UPPER ILS
3	245-810-101	UPPER ILS
3	245-811-101	UPPER ILS
3	245-812-101	UPPER ILS
3	245-813-101	UPPER ILS
3	245-814-101	UPPER ILS
3	245-815-101	UPPER ILS
3	245-816-101	UPPER ILS
3	245-817-101	UPPER ILS
3	245-818-101	UPPER ILS
3	245-819-101	UPPER ILS
3	245-820-101	UPPER ILS
3	245-821-101	UPPER ILS
3	245-822-101	UPPER ILS
3	245-823-101	UPPER ILS
3	245-824-101	UPPER ILS
3	245-825-101	UPPER ILS
3	245-826-101	UPPER ILS
3	245-827-101	UPPER ILS
3	245-828-101	UPPER ILS
3	245-829-101	UPPER ILS
3	245-830-101	UPPER ILS
3	245-831-101	UPPER ILS
3	245-832-101	UPPER ILS
3	245-833-101	UPPER ILS
3	245-834-101	UPPER ILS
3	245-835-101	UPPER ILS
3	245-836-101	UPPER ILS
3	245-837-101	UPPER ILS
3	245-838-101	UPPER ILS
3	245-839-101	UPPER ILS
3	245-840-101	UPPER ILS
3	245-841-101	UPPER ILS
3	245-842-101	UPPER ILS
3	245-843-101	UPPER ILS
3	245-844-101	UPPER ILS
3	245-845-101	UPPER ILS
3	245-846-101	UPPER ILS
3	245-847-101	UPPER ILS
3	245-848-101	UPPER ILS
3	245-849-101	UPPER ILS
3	245-850-101	UPPER ILS
3	245-851-101	UPPER ILS
3	245-852-101	UPPER ILS
3	245-853-101	UPPER ILS
3	245-854-101	UPPER ILS
3	245-855-101	UPPER ILS
3	245-856-101	UPPER ILS
3	245-857-101	UPPER ILS
3	245-858-101	UPPER ILS
3	245-859-101	UPPER ILS
3	245-860-101	UPPER ILS
3	245-861-101	UPPER ILS
3	245-862-101	UPPER ILS
3	245-863-101	UPPER ILS
3	245-864-101	UPPER ILS
3	245-865-101	UPPER ILS
3	245-866-101	UPPER ILS
3	245-867-101	UPPER ILS
3	245-868-101	UPPER ILS
3	245-869-101	UPPER ILS
3	245-870-101	UPPER ILS
3	245-871-101	UPPER ILS
3	245-872-101	UPPER ILS
3	245-873-101	UPPER ILS
3	245-874-101	UPPER ILS
3	245-875-101	UPPER ILS
3	245-876-101	UPPER ILS
3	245-877-101	UPPER ILS
3	245-878-101	UPPER ILS
3	245-879-101	UPPER ILS
3	245-880-101	UPPER ILS
3	245-881-101	UPPER ILS
3	245-882-101	UPPER ILS
3	245-883-101	UPPER ILS
3	245-884-101	UPPER ILS
3	245-885-101	UPPER ILS
3	245-886-101	UPPER ILS
3	245-887-101	UPPER ILS
3	245-888-101	UPPER ILS
3	245-889-101	UPPER ILS
3	245-890-101	UPPER ILS
3	245-891-101	UPPER ILS
3	245-892-101	UPPER ILS
3	245-893-101	UPPER ILS
3	245-894-101	UPPER ILS
3	245-895-101	UPPER ILS
3	245-896-101	UPPER ILS
3	245-897-101	UPPER ILS
3	245-898-101	UPPER ILS
3	245-899-101	UPPER ILS
3	245-900-101	UPPER ILS
3	245-901-101	UPPER ILS
3	245-902-101	UPPER ILS
3	245-903-101	UPPER ILS

STANDARD TOLERANCE INFO ON DR. SEE 016 DIMENSIONS ARE IN INCHES
TOLERANCES - UNLESS SPECIFIED - ±.03

ABB Power T & D Company, Inc.
Distribution Systems Division
245-903
DATE: 3/12/12
BY: [Signature]
CHECKED: [Signature]
APPROVED: [Signature]

Back Connect Kit

27 kV : 200 / 600 A : 40 kA

STANDARD TOLERANCE UNLESS NOTED OTHERWISE DIMENSIONS ARE IN INCHES
TOLERANCES - UNLESS SPECIFIED - ±.03

ITEM	ITEM PART No.	DESCRIPTION
1	546-000-000	UPPER BUS BRACE
2	54500-100	UPPER BUS
3	54500-100	UPPER BUS
4	54500-100	UPPER BUS
5	54500-100	UPPER BUS
6	54500-100	UPPER BUS
7	54500-100	UPPER BUS
8	54500-100	UPPER BUS
9	54500-100	UPPER BUS
10	545-000-000	SPACER
11	545-000-000	SPACER
12	545-000-000	SPACER
13	545-000-000	SPACER
14	545-000-000	SPACER
15	545-000-000	SPACER
16	545-000-000	SPACER
17	545-000-000	SPACER
18	545-000-000	SPACER
19	545-000-000	SPACER
20	545-000-000	SPACER
21	545-000-000	SPACER
22	545-000-000	SPACER
23	545-000-000	SPACER
24	545-000-000	SPACER
25	545-000-000	SPACER
26	545-000-000	SPACER
27	545-000-000	SPACER
28	545-000-000	SPACER
29	545-000-000	SPACER
30	545-000-000	SPACER
31	545-000-000	SPACER
32	545-000-000	SPACER
33	545-000-000	SPACER
34	545-000-000	SPACER
35	545-000-000	SPACER
36	545-000-000	SPACER
37	545-000-000	SPACER
38	545-000-000	SPACER
39	545-000-000	SPACER
40	545-000-000	SPACER
41	545-000-000	SPACER
42	545-000-000	SPACER
43	545-000-000	SPACER
44	545-000-000	SPACER
45	545-000-000	SPACER
46	545-000-000	SPACER
47	545-000-000	SPACER
48	545-000-000	SPACER
49	545-000-000	SPACER
50	545-000-000	SPACER
51	545-000-000	SPACER
52	545-000-000	SPACER
53	545-000-000	SPACER
54	545-000-000	SPACER
55	545-000-000	SPACER
56	545-000-000	SPACER
57	545-000-000	SPACER
58	545-000-000	SPACER
59	545-000-000	SPACER
60	545-000-000	SPACER
61	545-000-000	SPACER
62	545-000-000	SPACER
63	545-000-000	SPACER
64	545-000-000	SPACER
65	545-000-000	SPACER
66	545-000-000	SPACER
67	545-000-000	SPACER
68	545-000-000	SPACER
69	545-000-000	SPACER
70	545-000-000	SPACER
71	545-000-000	SPACER
72	545-000-000	SPACER
73	545-000-000	SPACER
74	545-000-000	SPACER
75	545-000-000	SPACER
76	545-000-000	SPACER
77	545-000-000	SPACER
78	545-000-000	SPACER
79	545-000-000	SPACER
80	545-000-000	SPACER
81	545-000-000	SPACER
82	545-000-000	SPACER
83	545-000-000	SPACER
84	545-000-000	SPACER
85	545-000-000	SPACER
86	545-000-000	SPACER
87	545-000-000	SPACER
88	545-000-000	SPACER
89	545-000-000	SPACER
90	545-000-000	SPACER
91	545-000-000	SPACER
92	545-000-000	SPACER
93	545-000-000	SPACER
94	545-000-000	SPACER
95	545-000-000	SPACER
96	545-000-000	SPACER
97	545-000-000	SPACER
98	545-000-000	SPACER
99	545-000-000	SPACER
100	545-000-000	SPACER

BACK CONNECT KIT
27 kV VERSARUPTER

ABB
Power T & D Company, Inc.
Pittsburgh, Pennsylvania, U.S.A.

REV. 10/2004
DATE: 10/2004
BY: [Signature]
CHECKED: [Signature]
APPROVED: [Signature]

FIG. NO. 245-904
REV. 10/2004
DATE: 10/2004
BY: [Signature]
CHECKED: [Signature]
APPROVED: [Signature]

Back Connect Kit

15 kV : 600 A : 61 kA

STANDARD TOLERANCE UNLESS OTHERWISE SPECIFIED - DIMENSIONS ARE IN INCHES

QTY	ITEM NO.	DESCRIPTION
1	1	245-891-001 UPPER BUS BRACE
1	2	245895-001 LOWER BUS BRACE
3	3	245892-K01 UPPER BUS
3	4	245893-K01 LOWER BUS
3	5	245-908-001 STANDOFF INSULATOR
3	6	54390-002 1/2-13 .53" LONG BOLT
6	7	54500-1000 1/2" WASHER
6	8	245-900-002 SPACER
6	12	245-899-002 WASHER
3	3	54390-005 1/2-13 X1.25 LONG BOLT

BACK CONNECT KIT
61 KA VERSARUPTER

ABB Power T & D Company, Inc.
Distribution Service Division
245-906 2
REV. 3/12/12
DATE 3/12/12
BY 3/12/12
APP. 3/12/12
CHECK BY
SCALE
MATERIALS
MANUFACTURING
ASSEMBLY
TESTING
INSPECTION
REVISIONS

Auxiliary Switch Kit

NOTE:

1. MOUNT CORRECT SUPPORT BRACKET FIRST USING ITEMS 5 & 6.
2. MOUNT CORRECT AUXILIARY SWITCH NEXT USING ITEMS 3 & 4.
3. MOUNT CORRECT CONNECTING LINK TO AUXILIARY SWITCH AND VERSARUPTER LAST, BY USING WASHER, HAIRPIN COTTER, AND ITEMS 9 & 10.

KIT NO. 244-006-517 (8 CIRCUIT)

QTY	ITEM	DESCRIPTION
1	1	321-987-305 AUX. SWITCH W/ CRANK ASSY.
1	2	321-097-001 SUPPORT BRACKET
2	2	54390-A01 SCREW, HEX HD (1/4-20 x 1/2 LG)
2	2	53103-F00 LOCKWASHER (1/4)
2	2	16908-P00 MB x 1.25/16mm LG
2	2	53103-G00 LOCKWASHER (5/16)
2	2	64488-688 NUT, HEX (5/16-18)
1	1	183-771-001 LINK, CONNECTING
1	1	65048-E00 RETAINING RING, TRIJARC "E" RING
1	1	54500-G00 FLATWASHER (.344 ID x .688 OD)
1	1	321-097-002 SUPPORT BRACKET
1	1	321-987-307 AUX. SWITCH W/ CRANK ASSY.
1	1	13 244-086-001 LINK, CONNECTING (38 KV)
1	1	244-087-001 SUPPORT BRACKET, 6 - POLE
1	1	244-087-002 SUPPORT BRACKET, 8 - POLE

REV	VERSA-RUPTER	REV	REV	REV	REV	REV	REV
1		1	1	1	1	1	1
DATE	DATE	DATE	DATE	DATE	DATE	DATE	DATE
12/2/85	12/2/85	12/2/85	12/2/85	12/2/85	12/2/85	12/2/85	12/2/85
BY	BY	BY	BY	BY	BY	BY	BY
REVISION DESCRIPTION		REVISION DESCRIPTION		REVISION DESCRIPTION		REVISION DESCRIPTION	
1 10/1/88 ITEM 9 WAS 53152-G		1 10/1/88 ITEM 9 WAS 53152-G		1 10/1/88 ITEM 9 WAS 53152-G		1 10/1/88 ITEM 9 WAS 53152-G	
2 4/23/88 (787) ADDED KIT NO 515 & ITEMS 11 & 12		2 4/23/88 (787) ADDED KIT NO 515 & ITEMS 11 & 12		2 4/23/88 (787) ADDED KIT NO 515 & ITEMS 11 & 12		2 4/23/88 (787) ADDED KIT NO 515 & ITEMS 11 & 12	
3 9/12/88 (863) -518 WAS 6 CIR.; -515 WAS 6 CIR.		3 9/12/88 (863) -518 WAS 6 CIR.; -515 WAS 6 CIR.		3 9/12/88 (863) -518 WAS 6 CIR.; -515 WAS 6 CIR.		3 9/12/88 (863) -518 WAS 6 CIR.; -515 WAS 6 CIR.	
4 2/14/93 (3227) + ASSY'S 514 & 517		4 2/14/93 (3227) + ASSY'S 514 & 517		4 2/14/93 (3227) + ASSY'S 514 & 517		4 2/14/93 (3227) + ASSY'S 514 & 517	
5 2/12/97 (5033) CAD, ITEM 5 WAS 54390L, -ITEM 7, NOTES 1-3		5 2/12/97 (5033) CAD, ITEM 5 WAS 54390L, -ITEM 7, NOTES 1-3		5 2/12/97 (5033) CAD, ITEM 5 WAS 54390L, -ITEM 7, NOTES 1-3		5 2/12/97 (5033) CAD, ITEM 5 WAS 54390L, -ITEM 7, NOTES 1-3	

5 AUXILIARY SWITCH KIT

ABB Power T&D Company Inc.
FLORENCE, S.C., U.S.A.

Chain Drive Assembly

FIG. 1 PARTS LIST (L.H. AND R.H. ASSEMBLY)

QTY.	PART NO.	DESCRIPTION
1	386-088-301	SPROCKET & Hub Assy.
1	650107-E	SPROCKET (250-20 X .25 L&D)
1	650107-F	SPROCKET (250-20 X .25 L&D)
1	650107-G	SPROCKET (250-20 X .25 L&D)
1	5317-C-001	CHAIN GUARD (250-20 X .25 L&D)
1	5317-C-002	CHAIN GUARD (250-20 X .25 L&D)
1	5317-C-003	CHAIN GUARD (250-20 X .25 L&D)
1	5317-C-004	CHAIN GUARD (250-20 X .25 L&D)
1	5317-C-005	CHAIN GUARD (250-20 X .25 L&D)
1	5317-C-006	CHAIN GUARD (250-20 X .25 L&D)
1	5317-C-007	CHAIN GUARD (250-20 X .25 L&D)
1	5317-C-008	CHAIN GUARD (250-20 X .25 L&D)
1	5317-C-009	CHAIN GUARD (250-20 X .25 L&D)
1	5317-C-010	CHAIN GUARD (250-20 X .25 L&D)
1	5317-C-011	CHAIN GUARD (250-20 X .25 L&D)
1	5317-C-012	CHAIN GUARD (250-20 X .25 L&D)
1	5317-C-013	CHAIN GUARD (250-20 X .25 L&D)
1	5317-C-014	CHAIN GUARD (250-20 X .25 L&D)
1	5317-C-015	CHAIN GUARD (250-20 X .25 L&D)
1	5317-C-016	CHAIN GUARD (250-20 X .25 L&D)
1	5317-C-017	CHAIN GUARD (250-20 X .25 L&D)
1	5317-C-018	CHAIN GUARD (250-20 X .25 L&D)
1	5317-C-019	CHAIN GUARD (250-20 X .25 L&D)
1	5317-C-020	CHAIN GUARD (250-20 X .25 L&D)
1	5317-C-021	CHAIN GUARD (250-20 X .25 L&D)
1	5317-C-022	CHAIN GUARD (250-20 X .25 L&D)
1	5317-C-023	CHAIN GUARD (250-20 X .25 L&D)
1	5317-C-024	CHAIN GUARD (250-20 X .25 L&D)
1	5317-C-025	CHAIN GUARD (250-20 X .25 L&D)
1	5317-C-026	CHAIN GUARD (250-20 X .25 L&D)
1	5317-C-027	CHAIN GUARD (250-20 X .25 L&D)
1	5317-C-028	CHAIN GUARD (250-20 X .25 L&D)
1	5317-C-029	CHAIN GUARD (250-20 X .25 L&D)
1	5317-C-030	CHAIN GUARD (250-20 X .25 L&D)
1	5317-C-031	CHAIN GUARD (250-20 X .25 L&D)
1	5317-C-032	CHAIN GUARD (250-20 X .25 L&D)
1	5317-C-033	CHAIN GUARD (250-20 X .25 L&D)
1	5317-C-034	CHAIN GUARD (250-20 X .25 L&D)
1	5317-C-035	CHAIN GUARD (250-20 X .25 L&D)
1	5317-C-036	CHAIN GUARD (250-20 X .25 L&D)
1	5317-C-037	CHAIN GUARD (250-20 X .25 L&D)
1	5317-C-038	CHAIN GUARD (250-20 X .25 L&D)
1	5317-C-039	CHAIN GUARD (250-20 X .25 L&D)
1	5317-C-040	CHAIN GUARD (250-20 X .25 L&D)
1	5317-C-041	CHAIN GUARD (250-20 X .25 L&D)
1	5317-C-042	CHAIN GUARD (250-20 X .25 L&D)
1	5317-C-043	CHAIN GUARD (250-20 X .25 L&D)
1	5317-C-044	CHAIN GUARD (250-20 X .25 L&D)
1	5317-C-045	CHAIN GUARD (250-20 X .25 L&D)
1	5317-C-046	CHAIN GUARD (250-20 X .25 L&D)
1	5317-C-047	CHAIN GUARD (250-20 X .25 L&D)
1	5317-C-048	CHAIN GUARD (250-20 X .25 L&D)
1	5317-C-049	CHAIN GUARD (250-20 X .25 L&D)
1	5317-C-050	CHAIN GUARD (250-20 X .25 L&D)
1	5317-C-051	CHAIN GUARD (250-20 X .25 L&D)
1	5317-C-052	CHAIN GUARD (250-20 X .25 L&D)
1	5317-C-053	CHAIN GUARD (250-20 X .25 L&D)
1	5317-C-054	CHAIN GUARD (250-20 X .25 L&D)
1	5317-C-055	CHAIN GUARD (250-20 X .25 L&D)
1	5317-C-056	CHAIN GUARD (250-20 X .25 L&D)
1	5317-C-057	CHAIN GUARD (250-20 X .25 L&D)
1	5317-C-058	CHAIN GUARD (250-20 X .25 L&D)
1	5317-C-059	CHAIN GUARD (250-20 X .25 L&D)
1	5317-C-060	CHAIN GUARD (250-20 X .25 L&D)
1	5317-C-061	CHAIN GUARD (250-20 X .25 L&D)
1	5317-C-062	CHAIN GUARD (250-20 X .25 L&D)
1	5317-C-063	CHAIN GUARD (250-20 X .25 L&D)
1	5317-C-064	CHAIN GUARD (250-20 X .25 L&D)
1	5317-C-065	CHAIN GUARD (250-20 X .25 L&D)
1	5317-C-066	CHAIN GUARD (250-20 X .25 L&D)
1	5317-C-067	CHAIN GUARD (250-20 X .25 L&D)
1	5317-C-068	CHAIN GUARD (250-20 X .25 L&D)
1	5317-C-069	CHAIN GUARD (250-20 X .25 L&D)
1	5317-C-070	CHAIN GUARD (250-20 X .25 L&D)
1	5317-C-071	CHAIN GUARD (250-20 X .25 L&D)
1	5317-C-072	CHAIN GUARD (250-20 X .25 L&D)
1	5317-C-073	CHAIN GUARD (250-20 X .25 L&D)
1	5317-C-074	CHAIN GUARD (250-20 X .25 L&D)
1	5317-C-075	CHAIN GUARD (250-20 X .25 L&D)
1	5317-C-076	CHAIN GUARD (250-20 X .25 L&D)
1	5317-C-077	CHAIN GUARD (250-20 X .25 L&D)
1	5317-C-078	CHAIN GUARD (250-20 X .25 L&D)
1	5317-C-079	CHAIN GUARD (250-20 X .25 L&D)
1	5317-C-080	CHAIN GUARD (250-20 X .25 L&D)
1	5317-C-081	CHAIN GUARD (250-20 X .25 L&D)
1	5317-C-082	CHAIN GUARD (250-20 X .25 L&D)
1	5317-C-083	CHAIN GUARD (250-20 X .25 L&D)
1	5317-C-084	CHAIN GUARD (250-20 X .25 L&D)
1	5317-C-085	CHAIN GUARD (250-20 X .25 L&D)
1	5317-C-086	CHAIN GUARD (250-20 X .25 L&D)
1	5317-C-087	CHAIN GUARD (250-20 X .25 L&D)
1	5317-C-088	CHAIN GUARD (250-20 X .25 L&D)
1	5317-C-089	CHAIN GUARD (250-20 X .25 L&D)
1	5317-C-090	CHAIN GUARD (250-20 X .25 L&D)
1	5317-C-091	CHAIN GUARD (250-20 X .25 L&D)
1	5317-C-092	CHAIN GUARD (250-20 X .25 L&D)
1	5317-C-093	CHAIN GUARD (250-20 X .25 L&D)
1	5317-C-094	CHAIN GUARD (250-20 X .25 L&D)
1	5317-C-095	CHAIN GUARD (250-20 X .25 L&D)
1	5317-C-096	CHAIN GUARD (250-20 X .25 L&D)
1	5317-C-097	CHAIN GUARD (250-20 X .25 L&D)
1	5317-C-098	CHAIN GUARD (250-20 X .25 L&D)
1	5317-C-099	CHAIN GUARD (250-20 X .25 L&D)
1	5317-C-100	CHAIN GUARD (250-20 X .25 L&D)

FIG. 1 CHAIN DRIVE ASSEMBLY

DETAIL A: ASSEMBLY OF CHAIN & THROBBLER

DETAIL B: VARIABLE SPEED ADJUSTMENT (L.H. & R.H. ONLY)

DETAIL C: VARIABLE SPEED ADJUSTMENT (L.H. & R.H. ONLY)

DETAIL D: VARIABLE SPEED ADJUSTMENT (L.H. & R.H. ONLY)

DETAIL E: VARIABLE SPEED ADJUSTMENT (L.H. & R.H. ONLY)

DETAIL F: VARIABLE SPEED ADJUSTMENT (L.H. & R.H. ONLY)

FIG. 2 CHAIN DRIVE ASSEMBLY (L.H. AND R.H. ASSY.)

FIG. 3 CHAIN DRIVE ASSEMBLY (L.H. AND R.H. ASSY.)

INSTALLATION AND OPERATION INSTRUCTIONS:

1. Before installing Chain and Operation Barrels, SWITCH CLOSED AND HANDLE IN THE UP POSITION.
2. HANDLE ASSY. (ITEM No. 22 OR 23) IS USED WITH HANDLE (ITEMS 24 OR 27). THE PLATED HOLES TO ADJUST TO DESIRED LENGTH, THE TOP OR BOTTOM HOLES ON HANDLE BARRELS.
3. SEE FIG. 5-20165 FOR INSTALLATION OF L.H. SWITCH EXTENSION KIT.
4. THROBBLER TO BE NO CLOSER THAN 1/2" TO EITHER SPROCKET IN SWITCH CLOSED POSITION WITH HANDLE SPROCKET OUT OF CLINK WITH HANDLE SPROCKET, IN UP POSITION. CAUTION: MAKE SURE CHAIN HAS SUFFICIENT CLEARANCE FROM INDENTED PARTS OUTSIDE OF SWITCH BARREL.
5. ADJUST CHAIN BETWEEN SWITCH AND HANDLE UNTIL TOP AND BOTTOM LIMITS OF CHAIN ARE BRING OPEN AND CLOSED POSITION. THE HANDLE SHOULD BE APPROX. 1/2" TO 3/4" FROM HANDLE STOP IN EITHER POSITION WHEN SWITCH TRIPS.
6. HANDLE ASSEMBLY SHOULD BE INSTALLED PRIOR TO HANDLE INSTALLATION.

FIG. 4 CHAIN DRIVE ASSEMBLY (L.H. AND R.H. ASSY.)

FIG. 5 CHAIN DRIVE ASSEMBLY (L.H. AND R.H. ASSY.)

FIG. 6 CHAIN DRIVE ASSEMBLY (L.H. AND R.H. ASSY.)

FIG. 7 CHAIN DRIVE ASSEMBLY (L.H. AND R.H. ASSY.)

FIG. 8 CHAIN DRIVE ASSEMBLY (L.H. AND R.H. ASSY.)

FIG. 9 CHAIN DRIVE ASSEMBLY (L.H. AND R.H. ASSY.)

FIG. 10 CHAIN DRIVE ASSEMBLY (L.H. AND R.H. ASSY.)

FIG. 11 CHAIN DRIVE ASSEMBLY (L.H. AND R.H. ASSY.)

FIG. 12 CHAIN DRIVE ASSEMBLY (L.H. AND R.H. ASSY.)

FIG. 13 CHAIN DRIVE ASSEMBLY (L.H. AND R.H. ASSY.)

FIG. 14 CHAIN DRIVE ASSEMBLY (L.H. AND R.H. ASSY.)

FIG. 15 CHAIN DRIVE ASSEMBLY (L.H. AND R.H. ASSY.)

FIG. 16 CHAIN DRIVE ASSEMBLY (L.H. AND R.H. ASSY.)

FIG. 17 CHAIN DRIVE ASSEMBLY (L.H. AND R.H. ASSY.)

FIG. 18 CHAIN DRIVE ASSEMBLY (L.H. AND R.H. ASSY.)

FIG. 19 CHAIN DRIVE ASSEMBLY (L.H. AND R.H. ASSY.)

FIG. 20 CHAIN DRIVE ASSEMBLY (L.H. AND R.H. ASSY.)

FIG. 21 CHAIN DRIVE ASSEMBLY (L.H. AND R.H. ASSY.)

FIG. 22 CHAIN DRIVE ASSEMBLY (L.H. AND R.H. ASSY.)

FIG. 23 CHAIN DRIVE ASSEMBLY (L.H. AND R.H. ASSY.)

FIG. 24 CHAIN DRIVE ASSEMBLY (L.H. AND R.H. ASSY.)

FIG. 25 CHAIN DRIVE ASSEMBLY (L.H. AND R.H. ASSY.)

FIG. 26 CHAIN DRIVE ASSEMBLY (L.H. AND R.H. ASSY.)

FIG. 27 CHAIN DRIVE ASSEMBLY (L.H. AND R.H. ASSY.)

FIG. 28 CHAIN DRIVE ASSEMBLY (L.H. AND R.H. ASSY.)

FIG. 29 CHAIN DRIVE ASSEMBLY (L.H. AND R.H. ASSY.)

FIG. 30 CHAIN DRIVE ASSEMBLY (L.H. AND R.H. ASSY.)

Left Hand Shaft Extension

BBC Brown Boveri

VERSARUPTER

L. H. SHAFT EXTENSION KIT ASSY. (W/HARDWARE KIT)

S-20185

(3 POLES)

REV. 1

SHEET NO. 1 OF 1

DATE 2-19-88

BY *[Signature]*

CHD. DATE 3-31-88

MICRO.

S.O.

THIS DRAWING IS THE PROPERTY OF BBC BROWN BOVERI INC. AND CONTAINS PROPRIETARY AND CONFIDENTIAL INFORMATION WHICH MUST NOT BE DUPLICATED, REPRODUCED, OR DISCLOSED OTHER THAN AS EXPRESSLY AUTHORIZED BY BBC BROWN BOVERI INC.

STANDARD TOLERANCE INFO ON DR 52014

TOLERANCES - UNLESS OTHERWISE SPECIFIED 3 PL. DEC. 3

DIMENSIONS ARE IN INCHES

3 PL. DEC. 3

NOTES:

- TO INSTALL SHAFT, INSERT & ROTATE SHAFT UNTIL SLOT ENGAGES MECHANISM. TAP IN PLACE UNTIL GROOVE FOR TRU-ARC RING IS CLOSE TO NYLON BEARING. TRU-ARC RING MUST BE FREE TO ROTATE BETWEEN NYLON BEARINGS.
- ITEMS NO. 7A, B, C, D, E, ARE PACKAGED WITH EACH SHAFT EXTENSION.

FRONT VIEW

- 1
- 2
- 3
- 4
- 5
- 6

ITEM NO.	PART NUMBER	DESCRIPTION	"P"		SERRATION		SHAFT LENGTH	
			MM	INCH	MM	INCH	MM	INCH
1	244-045-001	L. H. SHAFT EXT. (8.75 KV)	150	5.91	78	3.07	518	20.69
2	244-045-002	" (15.0 KV)	170	6.69	"	"	558	21.97
3	244-045-003	"	210	8.27	"	"	638	25.12
4	244-045-004	" (17.0 KV)	235	9.25	"	"	756	29.76
5	244-045-005	" (27.0 KV)	275	10.83	"	"	836	32.91
6	244-045-006	" (38.0 KV)	360	14.18	129	5.08	1172	46.14
7	186-073-001	HARDWARE KIT: (A) NUT, HEX (B) SPRINGWASHER (C) FLATWASHER (D) NYLON BEARING (E) RETAINING RING, TRUARC						
8	244-045-007	L. H. SHAFT EXT. (17.0 KV)	235	9.25	78	3.07	708	27.88

Mechanical Door Interlock

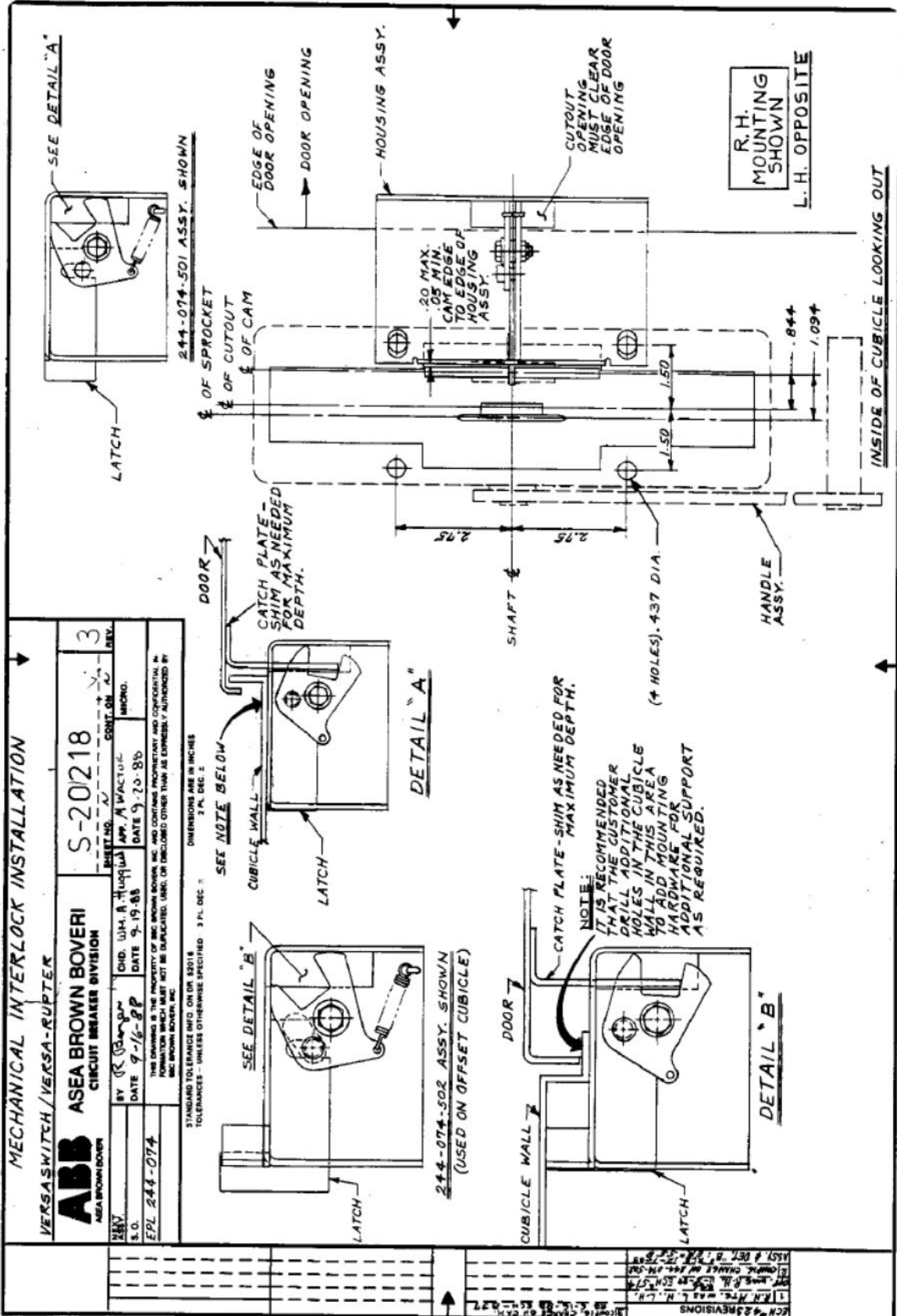

Direct Drive Handle Right Side

PARTS LIST (KIT NO. 244-063-501)

ITEM NO.	PART NO.	QTY.	DESCRIPTION
1	234-560-301	1	HANDLE (COMPLETE)
2	176-389-002	1	BEARING
3	178-744-001	2	INTERLOCK COVER PLATE
4	54382-C2	4	CAP SCREW, Hex Hd (3/8-16 x 5/8" LG.)
5	53119-H	4	LOCKWASHER (3/8")
6	177-867-301	1	COVER PLATE ASSY.
7	201-663-002	1	OPEN INDICATOR PLATE
8	201-663-001	1	CLOSED INDICATOR PLATE
9	176-356-002	1	SPACER
10	321-114-301	1	INTERLOCK Disc. & Hub Assy.
11	53113-H10	1	COTTER PIN (3/16" x 2 1/2" LG.)
12	50701-A79	4	FLATWASHER (3/8")
13	54400-H	4	NUT, HEX (3/8-16)

NOTES:

1. VERSA-RUPTER SWITCH TO BE IN THE CLOSED POSITION TO ATTACH THE DIRECT DRIVE OPERATION KIT ASSY.

PARTS LIST (KIT NO. 244-063-502)

ITEM NO.	PART NO.	QTY.	DESCRIPTION
1	234-560-303	1	HANDLE COMPLETE
2	176-389-002	1	BEARING
3	178-744-001	2	INTERLOCK COVER PLATE
4	54382-C2	4	CAP SCREW, HEX HEAD (3/8-16x5/8)
5	53119-H	4	LOCKWASHER (3/8)
6	177-867-303	1	COVER PLATE ASSY.
7	201-663-002	1	OPEN INDICATOR PLATE
8	201-663-001	1	CLOSED INDICATOR PLATE
9	176-356-002	1	SPACER
10	321-114-301	1	INTERLOCK DISCS. & HUB ASSY
11	53113-H10	1	COTTER PIN (3/16x2 1/2)
12	50701-A79	4	FLATWASHER (3/8)
13	54400-H	4	NUT, HEX (3/8-16)

CUT-OUT & DRILLING PLAN

REVISIONS

NO.	DATE	BY	REVISIONS
1	27.0	MSL	25.8
2	244-063-501	MSL	244-008-511
3	244-063-501	MSL	244-008-511

REVISIONS

NO.	DATE	BY	REVISIONS
1	27.0	MSL	25.8
2	244-063-501	MSL	244-008-511
3	244-063-501	MSL	244-008-511

REVISIONS

NO.	DATE	BY	REVISIONS
1	27.0	MSL	25.8
2	244-063-501	MSL	244-008-511
3	244-063-501	MSL	244-008-511

REVISIONS

NO.	DATE	BY	REVISIONS
1	27.0	MSL	25.8
2	244-063-501	MSL	244-008-511
3	244-063-501	MSL	244-008-511

REVISIONS

NO.	DATE	BY	REVISIONS
1	27.0	MSL	25.8
2	244-063-501	MSL	244-008-511
3	244-063-501	MSL	244-008-511

REVISIONS

NO.	DATE	BY	REVISIONS
1	27.0	MSL	25.8
2	244-063-501	MSL	244-008-511
3	244-063-501	MSL	244-008-511

REVISIONS

NO.	DATE	BY	REVISIONS
1	27.0	MSL	25.8
2	244-063-501	MSL	244-008-511
3	244-063-501	MSL	244-008-511

Provided by Northeast Power Systems, Inc.
www.nepsi.com

HE/HM Handles

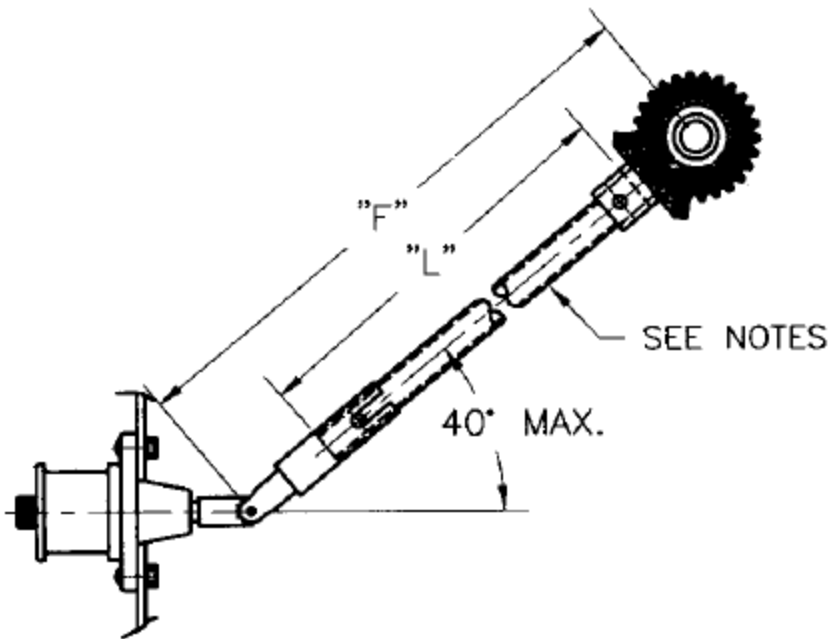

HM handle not shown

Follow same procedures for both operating handles

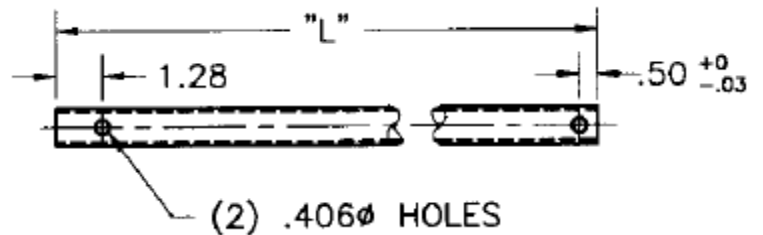

1. PIPE TO BE FURNISH BY CUSTOMER.
2. FOR LENGTHS LESS THAN 6.5 FT., .75" PIPE IS USED.
FOR LENGTHS EQUAL TO OR GREATER THAN 6.5 FT.,
1" PIPE IS USED.
3. LENGTH OF OPERATING ROD IS DETERMINED BY MEASURING
THE DISTANCE "F" AND CALCULATING LENGTH "L": $L=F-5.34$ ".
THE OPERATING ROD IS DRILLED PER FIG. 1 AND MOUNTED
BETWEEN BEVEL GEAR AND FRT. BRG./JOINT.

Notes

Contact Us

ABB Inc.

655 Century Point

Lake Mary, FL 32746

Phone: +1 407 732 2000

Customer service +1 800 929 7947 ext. 5

+1 407 732 2000 ext. 2510

E-Mail: customer.service.group@us.abb.com

www.abb.com/mediumvoltage

All sales are subject to ABB Inc.

General Terms and Conditions of Sale.

While every effort has been made to assure accuracy, the information in this document is subject to change without notice.

© Copyright 2011 ABB Inc. All rights reserved.

IB 2.1.2.7-4A Rev E May 2013

Provided by Northeast Power Systems, Inc.
www.nepsi.com

Power and productivity
for a better world™

